

INSTRUCTION MANUAL NAGRA D



NAGRA-D REGISTRATION FORM

Please carefully fill in this page (IN CAPITAL LETTERS) and return it to us upon receipt of your NAGRA-D. We will then be able to send you upgrade pages for your manual, as well as inform you of future developments in software.

Please return this page to:

Kudelski SA
Route de Genève, 22
1033 CHESEAUX

SWITZERLAND

ATTN: Support Technique

NAGRA-D Serial Number : _____
Purchase date : _____
Your Name / dept. : _____
Company name : _____
Street Name / N° : _____
Town / City : _____
Zip / Postal code : _____
Country : _____

NAGRA DIGITAL

OPERATING INSTRUCTIONS

Chapter 1	Introduction
Chapter 2	Location of Keys / Connectors / Functions
Chapter 3	Operation / settings of the NAGRA-D
Chapter 4	Synchronization / Remote control
Chapter 5	NADCOM software
Chapter 6	Specifications
Chapter 7	Options and Accessories
INDEX	

KUDELSKI S.A., Route de Genève 22, 1033 Cheseaux, Switzerland.

TEL: + 41.21.732.01.01 FAX: + 41.21.732.01.00

GUARANTEE

NAGRA/KUDELSKI certifies that this instrument was thoroughly inspected and tested prior to leaving our factory and is in accordance with the data given in the accompanying test sheet.

We guarantee the products of our own manufacture against any defect arising from faulty manufacture for a period of one year from the date of delivery.

This guarantee covers the repair of confirmed defects or, if necessary, the replacement of the faulty parts, excluding all other indemnities.

All freight costs, as well as customs duty and other possible charges, are at the customer's expense.

Our guarantee remains valid in the event of emergency repairs or modification being made by the user. However we reserve the right to invoice the customer for any damage caused by an unqualified person or a false manoeuvre by the operator.

We decline any responsibility for any and all damages resulting, directly or indirectly, from the use of our products.

Other products sold by KUDELSKI S.A. are covered by the guarantee clauses of their respective manufacturers.

We decline any responsibility for damages resulting from the use of these products.

We reserve the right to modify the product, and / or the specifications without notice.

CHAPTER 1 : INTRODUCTION

Using This Manual.....	1
General Description	1
Tape Durations	2
Electrostatic Discharge	3
Tape Care / Handling.....	3
Head Cleaning	4
Footprint Of The Format	5
Longitudinal Tracks.	6
Tape Speed	7
Putting The Machine Into The Large Reels Position.....	8
Powering The Nagra-D.....	9

INTRODUCTION

USING THIS MANUAL

This instruction manual is designed to enable the operator to understand, and use the NAGRA-D. The basic principles of audio recording or digital technology are not covered, except where the concept within the NAGRA-D is different from that normally applied. The manual is broken down into chapters covering different aspects of the machine. At the end of the manual there is a comprehensive index, which should guide the operator to the correct page quickly. The pages are numbered from 1 to N for each chapter. If in the future there is a page to be added in the middle of a chapter, then the new page to be added will have a page number followed by a decimal point and then 1, 2 or 3 etc. For example if a page is to be added between pages 5 and 6 of a particular chapter then the new page will be numbered 5.1. This manual covering Version 2.03 software for the NAGRA-D replaces all previous editions.

GENERAL DESCRIPTION

The concept of the NAGRA-D was to build a truly professional machine based on a format that is reliable and lends itself well to archiving. The arguments regarding the format, choice of tape etc. are not covered here.

The NAGRA-D is a four channel digital audio recorder having 24 bits per sample recording on 6.35mm metal oxide tape. It accommodates the sampling frequencies of 32 kHz, 44.1 kHz and 48 kHz (with the on-board A/D converters) rendering it suitable for all types of professional recording applications. The NAGRA-D is transparent to the AES bus giving connection possibilities to a wide range of external digital equipment, which even give it the possibility of recording two channels at sampling frequencies of 64, 88.2 and 96 kHz using external A/D converters. The format of the NAGRA-D records 4.608×10^6 bits per second, meaning that on a 5" reel of tape contains 16.03×10^9 bits (16 giga bits) of data. The combination of selected tape speed and number of channels to be recorded gives tape durations to satisfy all applications.

TAPE DURATIONS

		48 kHz	44.1 kHz	32 kHz
5" reel	4 channel mode	1 hr.	1 hr. 05 mins.	1 hr 30 mins.
	2 channel mode	2 hrs.	2 hrs. 10 mins.	3 hrs.
7" reel	4 channel mode	2 hrs.	2 hrs. 10 mins.	3 hrs.
	2 channel mode	4 hrs.	4 hrs. 20 mins.	6 hrs.

Apart from the two AES digital inputs, four analog inputs are available for microphone input sources. If Line inputs are to be used, then either input attenuators (ND-LIA #10550) or the line input circuit (ND-IL #10323) must be fitted to the machine. When in microphone operation each of the four inputs is switchable between Dynamic, "T" powering, +12V phantom and +48V phantom. The signal levels are adjusted using the input sensitivity potentiometers, and the levels are indicated on the four microprocessor controlled meters.

The four head scanner (2 for recording and 2 for playback) allows read after write (off tape monitoring / confidence playback) which can be heard through the two, level adjustable, headphone outputs.

The three longitudinal tracks (Control, CUE and Time Code) give flexibility of operation and additional features never before seen in a professional recorder.

Microprocessor control of the entire machine gives almost limitless possibilities, not only as far as the digital recording is concerned, but also for external control, fault diagnosis, tape directory management etc., from a PC equipped with the NADCOM software (KSA # 10514)

This has been a brief outline of the machine, all the points mentioned here will be covered in more detail later.

NOTE: The NAGRA-D has few user selections / switches inside (except the type of CUE microphone to be used - factory selection is for the ND-CM and one bank of DIL switches on the direct amplifier, the use of which is covered under the relevant chapter). All other mode selections etc. are made via an external PC or by the MENU mode.

IMPORTANT NOTES

ELECTROSTATIC DISCHARGE

The NAGRA-D's electronic circuits are all SMD (Surface Mounted Devices) using CMOS and MECL technology, which renders them very susceptible to electrostatic discharge. These circuits are fully protected while installed in the machine, however if any of the circuits are to be disconnected and removed from the machine then the operator must at all times be connected to ground via a wrist bracelet, and the circuits must only be placed on a conductive mat also connected to ground. If circuits are to be transported for any reason then they must be kept in anti-static plastic bags at all times. All the circuits are printed with the international sign indicating the danger. Eproms can also be damaged if frequently handled therefore we suggest this earthing procedure whenever work is to be carried out on the NAGRA-D.

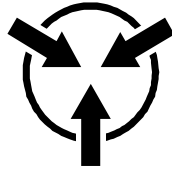

International symbol indicating static discharge danger

TAPE CARE / HANDLING

Although scissors editing is technically possible on the NAGRA-D, it is not recommended to touch the tape unless absolutely necessary. Cotton gloves are recommended in order to prevent moisture (finger prints) from the skin affecting the tape or clogging of the heads.

When certain tapes are rewound, the air trapped between the windings during rewinding can cause the tape to wind unevenly on the reel, meaning that the edges of the tape stand proud. If the plastic reel is then handled, there is a risk of physically damaging the edges of the tape. On the lower edge of the tape in the format of the NAGRA-D are the time code and Control track (see FORMAT) which will cause problems for playing back the tape if the edges of the tape are damaged. Normal winding speed in each direction is 4 m/s however slower winding can be selected in the MENU mode (1, 2, 3, 4 m/s).

ANALOG OUTPUT CONNECTIONS (TO A MIXER)

The NAGRA-D does not have transformers on its analog audio outputs. This means that if the outputs are to be connected to the inputs of a mixing console (For example so that the four channels can be mixed down to two) then be sure that the inputs to the mixer are set to the LINE position before the connection to the NAGRA-D is made. If they are set to the Phantom +48V position then the output OP-Amps of the NAGRA-D will almost certainly be damaged by the d.c. voltage coming from the microphone power supply of the mixer.

HEAD CLEANING

The NAGRA-D, like any tape recorder requires that the user clean the heads and other parts of the tape transport periodically. The frequency of this depends on many factors, such as the operating environment, the tape type, mechanical alignment of the machine's transport etc. as with any recorder. It is therefore difficult to give a specific time frame. As a guide, we suggest that the heads are cleaned once per day if the machine is being heavily used. However if the cloth does not appear to be dirty after cleaning, and no apparent problems have occurred then more time can be left before cleaning. If however the scanner etc. has been touched, and there are finger marks on it then the heads need to be cleaned immediately. Increasing error count in the ECC display gives an indication that the heads need to be cleaned.

Procedure

To clean the heads etc. firstly remove the tape and carefully clean the entry and exit guides of the scanner along with the longitudinal erase head and the longitudinal cue / control / TC head, using a soft cloth which has been dipped in alcohol (preferably MYTHYL alcohol but ISOPROPYL can also be used). Make sure that the ramp of the scanner is also perfectly clean as any deposit on this ramp will cause the tape path to be altered which can affect both recording and playback.

Once this has been done the rotary heads in the scanner can be cleaned. There are two different methods for doing this. The first is to hold the Alcohol soaked cloth against the surface of the scanner using your thumb, then gently rotating the scanner with the other hand while **keeping the cloth still**. The other is to lace a tape, put the machine in STOP, press RDY and then gently press the alcohol soaked cloth against the rotating scanner

NEVER MOVE VERTICALLY UP AND DOWN ON THE SCANNER AS THIS CAN BREAK THE HEADS. ALWAYS CLEAN THE SCANNER IN A HORIZONTAL MANNER.

NEVER USE Q-TIPS OR OTHER COTTON BUDS AS THEY WILL LEAVE HAIRS ON THE HEADS OF THE SCANNER.

ALWAYS ALLOW THE TRANSPORT TO DRY OFF AND THE ALCOHOL TO EVAPORATE BEFORE ENGAGING THE TAPE.

FOOTPRINT OF THE FORMAT

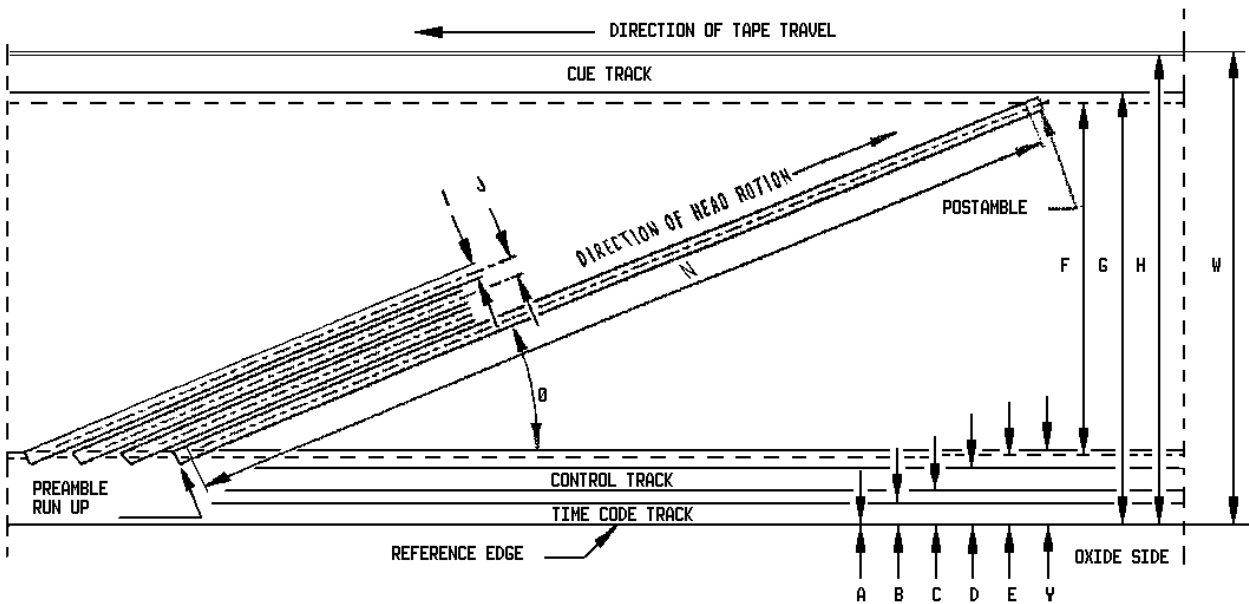

Diagram showing the track layout on the tape.

The NAGRA-D records information on the tape not only using the rotary heads in the scanner but also using longitudinal head. The "footprint" above shows the positioning of these various tracks on the tape. (diagram is not to scale).

A.	Time code track lower edge	Reference edge
B.	Time code track upper edge	0.300
C.	Control track lower edge	0.500
D.	Control track upper edge	0.800
E.	Digital data area lower edge (Ref. point)	0.900
F.	Digital data area width	4.650
G.	Cue track lower edge	5.700
H.	Cue track upper edge	6.200
I.	Helical track width	0.07
J.	Helical track pitch	80.70 μm
N.	Helical track data length	44.20
N.	Track angle	5.835°
W.	Overall tape width	6.250 (± 0.05)
Y.	Beginning of data	0.971

All measurements are in mm (unless otherwise specified) taken from the reference edge of the tape.

LONGITUDINAL TRACKS.

As shown in the diagram on the previous page there are three longitudinal tracks which are:

TIME CODE TRACK

The time code track is only recorded on machines equipped with the ND-TC (#10370) option, and assuming that the time code lock-out switches are in the ready position.

This is a longitudinal SMPTE/EBU 80 bits time code track recorded using Manchester Bi-phase which allows the reading of time code at very high speeds. The internal time code system of the NAGRA-D includes a time code generator corresponding to all the presently used formats (including drop frame). Time code can be recorded from the internal generator or an external source. Both the time and user information can be set from the keyboard or a PC. Although time code "Pre-striping" is permitted, recording of time code after the event (Post Striping) is not allowed as doing this will disturb the control track of the machine and will make the tape unreadable.

When in rapid winding (especially at half-speed) the time code passes the head at more than 60 times nominal speed and cannot be correctly read from the tape. In these instances the time code output and display is updated from the counter roller.

CONTROL TRACK

This track is similar to the control track of a video recorder. Data is automatically recorded along the tape, which serves as "markers" indicating the start point of each helical scan. The purpose of these "markers" is to enable the servo system of the NAGRA-D to synchronise the position of the heads of the scanner with respect to the position of the helical scan on the tape. This ensures that the heads track the helical scans accurately and do not read between the scans. This track cannot be accessed by the user and contains no user data.

If necessary, the alignment of this track can be adjusted using the TRACKING control in the OTHERSET menu.

CUE TRACK

The CUE track of the NAGRA-D is a low quality analogue track which has two principle functions:

1. In normal operation it will record a mix of the information being recorded on the 4 digital channels, from either the analogue or digital inputs, allowing rapid audible searching on the tape of a particular point in the recording. A cue microphone can also be recorded at the same time if desired. This is the normal mode and will operate as described whenever the machine is put into recording mode and the cue channel "lock out" switch is in the READY position. The output of the CUE track can only be monitored on the headphone outputs, if searching is being done at speeds other than nominal then the analogue and digital outputs of the NAGRA-D are muted. The Cue track output is automatically switched to the headphone outputs whenever the tape is not at nominal speed.
2. It can be used to record Cue information by means of a commentary microphone (ND-CM #10530), connected to the EXTENSION socket on the left-hand side of the machine. A standard dynamic microphone may be used instead of the ND-CM but an internal selection needs to be made on the CUE TRACK circuit, located next to the time code input connector. The switch should be towards the rear of the machine in order to use the ND-CM and towards the front of the machine for any other standard dynamic microphone.

Synoptic diagram of the cue track

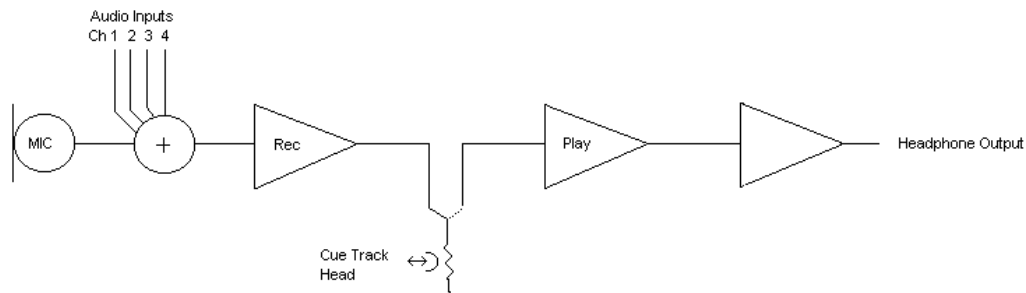

HELICAL TRACKS

Each helical track (or scan) on the tape contains the information coming from a pair of inputs (either 1+2 or 3+4). These tracks are made up of 192 sectors of digital information sent from the ECC (Error Correction Code). The shuffling used in the NAGRA-D means that it is perfectly possible to record channels 1+2 initially and then at a later date record channels 3+4 (or vice-versa) using the INSERT feature, providing that the machine is in the high speed four track mode. However it is not possible to record channels 1+3 and later 2+4 as this would require additional heads in the scanner allowing read before write.

The helical tracks of the NAGRA-D are recorded by a rotating scanner equipped with VHS heads, which rotates at 62.5 revolutions per second (3750 R.P.M. at a sampling frequency of 48 kHz.) and the track width of each scan is of 70µm.

TAPE SPEED

Two different longitudinal tape speeds are available, either 49.6 mm/s (approx. 2 ips.) for two track operation, giving 2 hrs of continuous recording with a 13 cm (5") reel (at 48 kHz sampling frequency), or 99.2 mm/s (approx. 4 ips.) for 4 channel operation giving approximately 1 hr of recording using a 13 cm (5") reel (at 48 kHz sampling frequency). Tape speed selection is made in the MENU mode, and the factory default setting is the high speed four track mode. The NAGRA-D will equally well operate with 18 cm (7") reels respectively doubling these recording times. The reel motors need to be rotated and a special cover (ND-SET #10520) needs to be fitted to the machine in order to use 7" reels. (Please refer to "Tape Durations" at the beginning of this section for a complete list of recording times depending on reel size and sampling frequency and tape speed).

PUTTING THE MACHINE INTO THE LARGE REELS POSITION

The NAGRA-D is delivered in the 5" reel configuration, but it can easily be moved to the 7" position. Before attempting to change the positions of the reel motors, the machine must be switched ON (without tape) in order to ensure that the parking brakes are released.

Loosen the two screws on the front of the main control panel so that the deck plate of the machine can be lifted (or the two thumb-screws if the ND-PP (#10560) potentiometer protection bar is fitted). Open the plexi-glass cover of the transport and remove the tape and the empty reel. Insert a 1.5mm Allen Key (for machines with 1000325 or lower) (a 2mm Allen key for machines with serial number higher than 1000325) into each of the three holes, in turn, around the reel motor to be moved. Loosen each screw in turn by **MAXIMUM HALF A REVOLUTION** then **REMOVE THE ALLEN KEY**. Lift the deck plate of the machine, and gently rotate the motor to the 7" position by turning the grey plastic cover of the reel motor. Once the motor is fully turned, and the marks on the deck plate are aligned with the 7" position indications then re-insert the Allen key and re-tighten the three screws.

The motors should rotate easily, if this is not the case then **DO NOT FORCE THEM**. If necessary contact your nearest dealer for assistance.

NOTE: If the screws are loosened more than half a turn it is possible that they will fall inside the machine. Secondly if the key is not removed when rotating the motor the parking brakes will be damaged.

It should also be noted that when in the 7" reel position, the slowing down of the reel motors during fast winding as it reaches the end of the tape does not operate. This is because the diameter of the central hub of a 7" reel is not the same as that of a 5" reel and the machine is unable to determine that the end of the reel is approaching.

It is recommended that the 7" reel cover ND-SET (#10520) be fitted to the machine if large reels are to be used. This is not only to protect the tape from the environment but also reduces the noise of the scanner substantially.

POWERING THE NAGRA-D

The NAGRA-D is a battery operated recorder and is fitted with an internal BP-90 battery pack, of the BETACAM™ style. This internal battery pack must be fitted to the machine at all times, as without the internal battery the machine will not operate even if connected to the external charger unit, or supply. A fully charged battery pack under normal circumstances will give approximately 2 hrs of continuous 4 channel recording. The NAGRA-D runs permanently off this internal battery pack, which acts as a buffer, even when connected to the charger.

The NAGRA-D's ND-CCC3 (10755) charger unit supplies a 40 mA trickle charge permanently to avoid reverse-polarisation of the cells in the battery pack. When the battery needs charging the charger is instructed to supply the 400 mA charge current. The internal battery will only be charged when the machine is in LOAD or PARK position. The NAGRA-D communicates with this charger and instructs it on the amount of current to supply, at any particular time. The status of the internal battery, in terms of residue etc. can be seen at any time on the LCD display in the MENU mode (see MENU's in chapter 3). The internal battery pack can be removed from the machine and charged on a normal BETACAM™ charger if desired. However if the internal battery is removed from the machine, then the memory and settings will be lost. A large capacitor will keep the internal settings for a couple of minutes. The machine will use default (WAKE UP) modes when powered up again. If settings have been saved in a "Template" (see menus) then these settings will not be lost and can be restored once a new battery is put into the machine.

NOTE : When the internal battery is replaced then the battery management system assumes that the new battery installed is already full and will indicate 100 % in the battery reserve menu. If however the operator knows that the new battery is only charged to 25, 50, or 75 % this can be stored in the memory of the machine in the menu mode and the machine will take this preset value into account from the start.

WARNING: The battery pack in the NAGRA-D is of the Betacam™ type fitted with a 2mm DC two pole connector (positive pole on the external connector) WITHOUT any form of internal electronic protection or control. Battery packs that are fitted with such internal surveillance electronics are fitted with a 3 pole connector that is physically too large to be connected inside the NAGRA-D.

It is recommended to run the internal battery completely flat from time to time to avoid any memory effect accumulating in the NiCd.

NOTE: As the internal battery is always inside the machine the life of the battery is shortened as it is charged at a temperature of about +40 °C. Meaning that if a full 2 hrs of recording time is needed on the internal battery then the battery must be replaced with one that has been externally charged. The effective life of the internal battery is reduced to about 1 h 20 min if left in the machine.

REMEMBER: THE INTERNAL BATTERY OF THE NAGRA-D WILL ONLY CHARGE WHEN THE MACHINE IS TURNED ON AND IN PARK OR LOAD POSITIONS.

There are several different powering methods other than A.C. the different possibilities are all discussed on the following pages.

EXTERNAL DC POWERING

The NAGRA-D can be powered from an external D.C. supply source assuming certain accessories are present.

USING THE INTERNAL ND-AP OPTION

The ND-AP (#10230) is an internally mounted circuit which allows the NAGRA-D to be powered from an external D.C. supply voltage from 11V to 14V max.

As mentioned previously, the NAGRA-D must always have an internal battery fitted. If the ND-AP option is installed in the machine then external batteries having a voltage between 11 and 14V (MAX) can be connected to the cable supplied with the option. The ND-APC cable (#10231) which is supplied with the ND-AP option is fitted with a LEMO connector on one end and a two pole female power jack connector on the other. The female power connector is wired in such a way that the external (positive) connection is wired to the CONTROL pin of the LEMO connector.

The ND-AP option will automatically select the external battery if it has a voltage greater than 11V, otherwise the internal battery will be used. The indication of the battery reserve in the menu display will increase while the external battery is being used but in fact this is meaningless as the actual state of the internal battery is not changing. In this mode of operation, **THE EXTERNAL BATTERY WILL NOT CHARGE THE INTERNAL BATTERY**, meaning that the internal battery of the machine will need to be periodically charged using an external charger.

IMPORTANT: Please note that the external battery must be connected to the **GROUND** and the **CONTROL** connections of the external power connector **NOT THE POSITIVE terminal**. If is not connected in this manner then the internal fuse of the NAGRA-D will blow.

THE ND-EPC (External DC/DC converter) OPTION

The NAGRA-D may be powered using the ND-EPC (#10505) external DC to DC converter. This accessory is fitted with a 4-pole male XLR socket, to which an external DC supply from 11 to 30V may be applied in either polarity.

The three pole LEMO connector connects to the POWER connector on the right-hand side of the machine, where the mains charger is normally connected. The external DC supply must be connected to the 4-pole male XLR connector on the side of the ND-EPC. It is recommended to connect the ND-EPC to the NAGRA-D before connecting the external DC supply to the unit.

Once connected, the ND-EPC will not only power the NAGRA-D from the external source, but **WILL ALSO CHARGE THE INTERNAL BATTERY OF THE MACHINE** in the same way the mains charger does. The charge current supplied by the ND-EPC is managed by the internal microprocessor of the NAGRA-D. The battery of the machine will only be charged if the NAGRA-D is powered up. During use the PWR flag on the display will be alight, and the BAT led will be off to indicate that the external power is being used. The four pin XLR connector should be wired between pins 1 and 4 in either polarity.

LED INDICATIONS OF THE ND-EPC

The "Input voltage" led indicates that the external DC supply is connected to the unit and that the NAGRA-D is switched ON. If the NAGRA-D is not connected to the unit then this led will blink.

The "Output Current" led indicates inversely with respect to the output current of the ND-EPC. It will be dimly lit if the current drain to the NAGRA-D is large (Maximum charging) and will be brightly lit if a small current is being drawn (battery fully charged).

Input Voltage LED	ON	- Nagra-d connected and switched ON
	BLINKING	- Nagra-d not connected
Output Current LED	BRIGHT	- Minimum charge. Internal battery 100%
	DIM	- Maximum charge going to NAGRA-D

FLOW CHART OF POWERING POSSIBILITIES

**POWERING
THE NAGRA-D**

ACTIONS

REMARKS

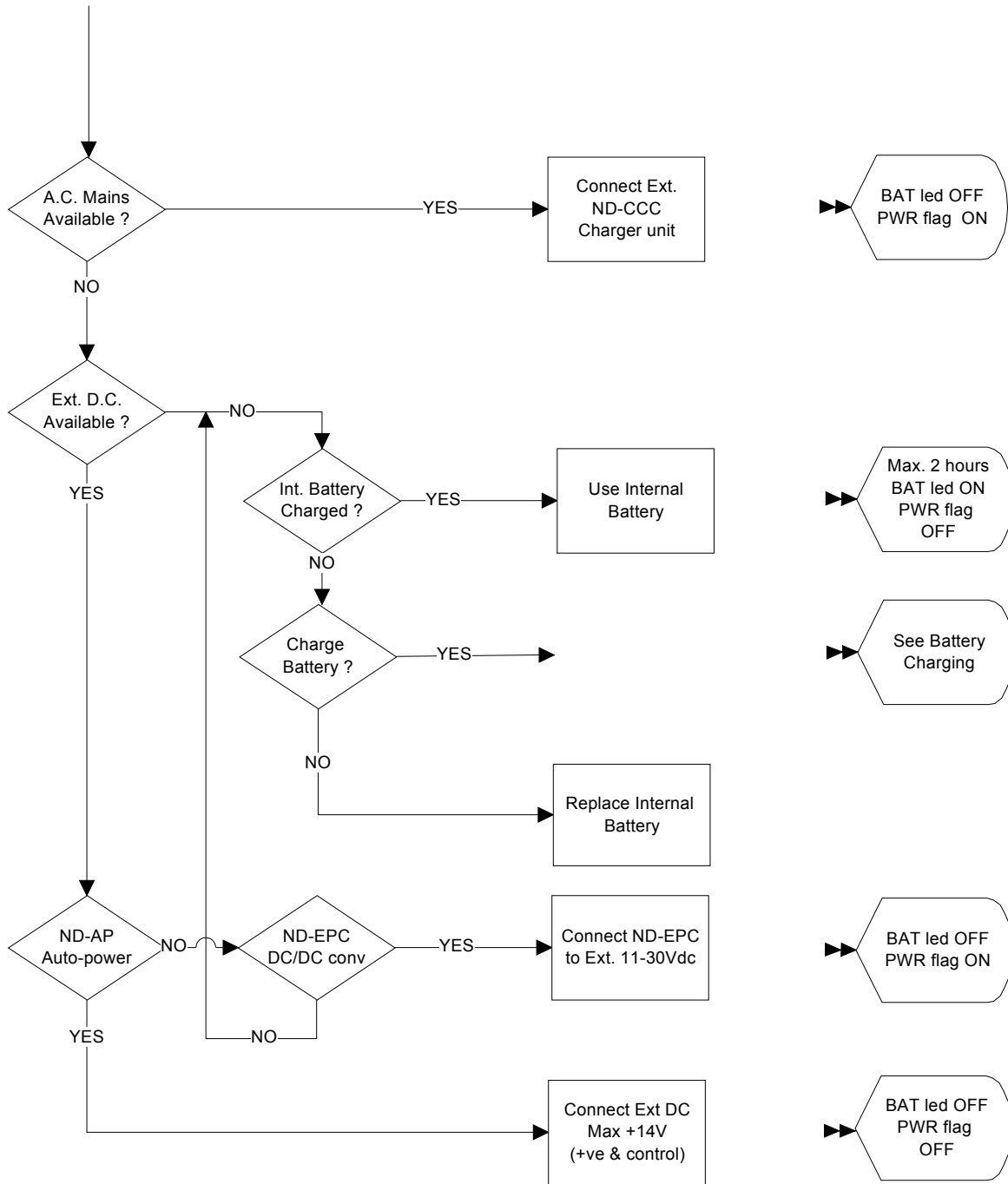

Chapter 2: LOCATION OF KEYS / CONNECTORS / FUNCTIONS

Description of parts located on:

Tape Deck	14
Main Control Panel.....	14
Front Face	26
Left-Hand Side Panel	29
Right-Hand Side Panel.....	32

TAPE DECK

(Refer to the photograph showing the NAGRA-D from above on the previous page) This shows the location of various mechanical parts referred to elsewhere in the manual.

<u>Pos</u>	<u>Description</u>
1	Supply reel holder
2	Take-up reel holder
3	Scanner (for recording helical tracks)
4	Tape tension roller and tape counter roller
5	Pinchroller
6	Capstan shaft
7	Tape engagement carriage
8	Longitudinal head (Cue, TC and Control track)
9	Full track erase head
10	Tape guide
11	Deck fastening screws
12	Hermetically sealed plexi-glass cover fixations

MAIN CONTROL PANEL

This section describes the operation of all the elements of the main control panel of the machine. (please refer to photograph on the following page)

<u>Pos</u>	<u>Description</u>
------------	--------------------

1. HEADPHONE SELECTION SWITCHES

The 4 headphone selection switches function in conjunction with the mode selector switch 2 and the direct switch 3. There are four switches (each corresponding to one channel) each having three positions. These positions are SOLO / ON / OFF. The SOLO position is a snap switch and must be held in the SOLO position. When held in the SOLO position the signal from the selected channel is centred on the headphone outputs, and the other channels are inhibited. The four (1, 2, 3, 4) headphone switches are also labelled L, R, L, R respectively. This means that if selector 1 is ON then the signal will be fed to the left channel of the headphone outputs. If selector 2 is ON then it will be fed to the right channel and so on. Thus having stereo monitoring between two channels is possible between the following combinations: 1+2, 1+4, 2+3 and 3+4. The combination of 1+3 is not possible as they would both be on the same channel superimposed. If the 96 kHz option is activated and the higher sampling rates are used then only selectors 1 and 3 are activated for left and right channels respectively and naturally the off tape or direct monitoring in the headphones is only at 48 kHz not 96 kHz due to the internal D/A converters.

2. HEADPHONE MODE SELECTOR

This three position switch selects the mode of the headphone outputs. The three positions correspond to MONO / STEREO / CUE. In the MONO or STEREO positions the audio signals are monitored in the respective format. In the CUE position the headphone outputs monitor the longitudinal CUE track (see CUE TRACK). Whenever the machine is not at nominal speed then the headphone output is automatically switched to the CUE track, as long as the EE / AUTO / TAPE switch is not in the EE position.

3. **EE / AUTO / TAPE SELECTOR**

This three position switch is the EE / AUTO / TAPE selector selects the monitoring for the machine.

EE = Direct signal all the time
AUTO = Direct signal when tape is stopped and "Off tape" when tape is moving
TAPE = Off tape all the time

In the EE position the signal on the headphone outputs is the INPUT (DIRECT) signal. When in the EE position there is no delay (caused by the DSP). In the EE position it is not possible to monitor the AES inputs

In the AUTO position the signal fed to the headphones will be the EE signal when the tape is not at nominal speed and will be the off tape signal when it is at nominal speed. In the AUTO position a delay will be heard if the tape is not moving.

When in the TAPE position monitoring is always the "off tape" signal when at high speed 4 track mode which gives confidence playback during recording. During record, even if the selector is in the EE position, the errors indicated on the display are still those of the tape. At half speed if the machine is not equipped with read after write at half speed and this selector is in the EE position then the ECC display will be errors of the internal DSP rather than the tape, and logically will always show 00.Fa. When the machine is the RECORD mode in 2 track operation (half speed) then the signal fed to the headphones is the EE signal irrespective whether the switch is in the AUTO or TAPE position unless the machine is fitted with a specially aligned scanner allowing read after write at half speed.

4. **DISPLAY ILLUMINATION SWITCH**

The brightness switch is used to light the back-lit display and the modulometers, as well as to change the intensity of the LEDs on the main control panel. It is a three position switch showing a sun, a cloud and a moon. The only position of this switch where the meters and the LCD display are illuminated is in the "moon" (night) position.

5. **METER SWITCH**

This is a three position switch, marked RESET HOLD / LEVEL / HOLD MAX. This is the selection for the operation and indication of the level meters.

LEVEL: The meters indicate the normal signal levels, either "off tape" or "input" depending upon whether the machine is in REPLAY or RECORD.

HOLD MAX: The meters and the ECC display will hold and remain fixed at the maximum level reached since the last reset. They will then increase as higher levels are detected. These max values are kept in memory and can be looked at when needed, by switching from LEVEL to HOLD MAX, on the main keyboard.

RESET HOLD: This momentary switch resets the MAX values of the ECC and the modulometers to zero. At the same time the display of the machine will scroll through the current internal settings. For machines equipped with the ND-TC (#10370) internal time code option, pressing the switch a second time, while the initial scrolling is being performed, will switch to the time code scroll indicating. The present settings of both the internal generator and the internal time code synchroniser will be shown (see time code chapter for the default settings and their explanations). Pressing any transport key will abort the scrolling menu mode.

6. **REC LEDS**

The red record LEDs will light when the selected channels are in the record mode. If the machine is put into record mode, and two channels are in the SAFE position while the edit

selector is in the ASS (assemble) position then the record LEDS of the channels in the SAFE position will flash to indicate to the operator that these two channels are being erased. The REC LEDS will also come on while the tape DIRECTORY is being recorded even if all four audio channels are in the SAFE position. (In 2 channel half speed operation then only channels 1 + 2 will go into record when the tape directory is being recorded).

7. METERS

The four meters are microprocessor controlled and indicate the audio levels either during record, or replay depending on the mode of the machine, and they are calibrated in dB. The controlling software gives the meters almost the same ballistics as a modulometer. The possible indications of these meters is selected by the mode selector 5 to either LEVEL or HOLD MAX. The fourth modulometer is also used to indicate the RF level of the tape when the TRACKING function is selected (see OTHERSET in the MENUS).

8. INPUT LEVEL SENSITIVITY ADJUSTMENT

The outer ring of the coaxial potentiometers is the input level sensitivity adjustment. These potentiometers act directly on the inputs and control the sensitivity of the analog inputs and hence incoming levels. These controls have no effect on the digital inputs.

9. FADER CONTROL

This inner knob of each of the coaxial potentiometers is the FADE control **and should be left in the centre (CAL) position at all times except when making a fade**, if the full dynamic range of the machine is to be used. The CAL position is indicated by the green CAL led 26. The fade commands are digital information recorded onto the tape and do not actually fade the incoming source material, which means that this "non-destructive" fading can be changed after the event, if required using the FADER SRC command in the menu mode.

The fourth fader control potentiometer is used for several different functions, each of which is listed and explained below.

- Fourth channel fader control
- Tape direction & speed in EDIT mode
- Offset modification (TC machines only)
- Manual tracking control.

It can be used to control the tape direction and speed when in the EDIT mode (EXE + PLAY) monitoring of which must be done on headphones.

If the machine is fitted with the ND-TC (#10370) time code option, then the fourth fader potentiometer can also be used to change the OFFSET between the time code reference and the time code recorded on the tape. When in this mode (see menus) the pot has a large central stop position, where the offset does not move. When turning the potentiometer there is initially a position where the offset will increase (or decrease depending on the direction that the pot is turned) at a rate of 2 bits per second. If the pot is turned a little further the offset will start to increase at a rate of 20 bits per second. If it is turned to its end-stop, then the offset will start to increase at a rate of 200 bits per second, (which corresponds to approx. 2.5 frames per second). This modify mode should only be used to find the sync point when very close. Larger offset modifications (minutes seconds) should be entered as values in the SET mode.

The fourth potentiometer can also be used as a tracking control, by pressing EXE when in the tracking menu. This allows the operator to change the relative position of the control track pulses with respect to the scanner, which is especially useful at half speed to ensure playback compatibility between machines. In this mode monitoring of the RF level is indicated on the fourth modulometer.

10. READY (RDY)



The RDY (ready) key will switch on the scanner (assuming that a tape is installed onto the machine and that neither of the tape tension rollers are at their outer extreme positions). This mode is the same as "scanner on" in a VTR. This has two main advantages. Firstly, once the ready mode is selected and the scanner is up to speed, then the machine can be put into playback or record very quickly. Secondly, the operation of starting the scanner draws more current from the internal battery the operating time using batteries alone can be extended when the machine is required to repeatedly switch between PLAY/REC and STOP. The scanner will stop automatically if the machine is left in this mode for 1 minute (duration is selectable in the OTHERSET menu) and the transport is in STOP mode. The ready function is automatically selected if the machine is put into PLAY or REC from stop, which means unless it is pressed again after STOP has been selected, then the scanner will continue to turn for 1 minute after the end of the REC or PLAY

RESET COUNTER COMMAND

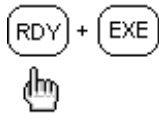

If the EXE key is held down while pressing the RDY key then RESET COUNTER will reset the internal tape counter to zero. This can be made during any mode of operation of the machine. It must be noted that the counter is in hours, minutes and seconds and is dependant upon the sampling frequency presently selected on the machine. Hence if the sampling frequency is changed half way through a tape then the counter value will instantly indicate as though the entire tape had been recorded at the presently selected sampling frequency.

11. RECORD (REC)



The REC (recording) key must be pressed in conjunction with the PLAY key to put the NAGRA-D into the recording mode, both the PLAY and REC LEDs will light. The channels that are to be recorded are selected according to the positions of the lockout switches (23). (if the edit switch is in the ASS position and the channels are selected to READY, the machine will go into the REC mode in order to record the control track only. If all the channels are in SAFE and the ASS/INS is in the INS position then the machine will not move and the REC led will flash to indicate that record has been selected but no channels have been selected.

GOTO END FUNCTION

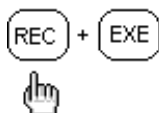

If the EXE key is held down while the REC key is pressed then the GOTO END feature is activated. This will automatically send the tape to the end of the last recorded track of the tape providing the tape has been recorded with a DIRECTORY. The GOTO END feature will not operate if the machine is already in the RECORD mode. If there is no directory then the machine will go to the end of the 99th take. It will stop slightly before the exact end so as to leave enough time for a correct pre-roll thus being sure that a correct track assemble edit is made when record is pressed. The take number will automatically be incremented each time the REC + PLAY keys are pressed. This can also be done without dropping out of record by simply pressing the two buttons again to create a new take number "on-the-fly", while the machine is recording.

RECORD PREVIOUS TAKE NUMBER

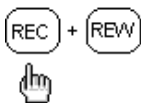

If the DIRECTORY mode is ON and REW + REC is pressed then the machine will go into record in the normal way but the take number will be that of the previous take recorded. The previous recording will be eliminated from the directory. This is used to eliminate "false starts" from the directory. The audio data from the previous take will remain on the tape but it will have no TAKE number and the display will indicate "/" if such a take is played back to indicate that the machine is between two recognised takes the counter will also be displayed.

NOTE:

The DIL switch Number 1 on the top left-hand side of the direct amplifier inside the machine is a record inhibit switch and will prevent the machine from recording if it is put into the ON position. If recording is attempted with this switch in the ON position then the display of the machine will indicate "Rec. Inh."

12. STOP



This is the main STOP key and will stop the machine from any transport mode except during the recording of the tape directory. Once pressed, the tape will be taken away from the scanner which will then stop rotating, unless the RDY (ready) key was pressed previously, then the scanner will continue to turn for 1 minute after the STOP key has been pressed (this duration can be selected in the menu mode). The machine is then in the "standby" mode. When in STOP the audio signal path is EE allowing level adjustment and audio monitoring. Access to all the status menus, and their modification is possible while in the STOP mode via the display keys located below the LCD. When a new tape is loaded on to the machine and the STOP key is pressed, then the machine will automatically start to look for the tape directory.

GOTO ZERO FEATURE



If the EXE key is held down while pressing STOP then the GOTO ZERO function is activated. The transport will go to the zero counter position.

13. PLAY



The PLAY key puts the machine into normal playback mode. If the EXE key is held down while the PLAY key is pressed then the machine will go into the EDIT mode and the PLAY led will flash. When in the edit mode, the fourth fader pot serves as a search control and will vary the speed and direction of the tape according to the rotational position of the pot. Monitoring during this mode is from the CUE track via the headphone outputs. Once the machine is at nominal speed the audio outputs are no longer muted and the line outputs can be monitored.

SEARCH FORWARD COMMAND

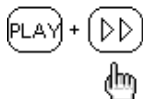

If either of the FF or REW transport keys are held down while in PLAY the machine will advance or reverse at four times nominal speed, and once the FF or REW key is released then the machine will continue in the playback mode at nominal speed. If pressed briefly and released the machine will advance at 4 times nominal until another function is selected. Pressing it again briefly will set the machine to 8 times nominal. An additional brief press when will toggle back to 4 times.

SEARCH BACKWARDS COMMAND

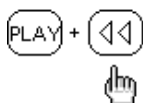

A brief depression of either FF or REW will put the machine to 4 times nominal speed until play is pressed again. A second brief press will put the machine to 8 times nominal speed. An additional brief press when will toggle back to 4 times.

CHASE SYNCHRONISE MODE

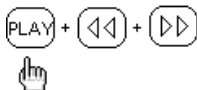

If the ND-TC time code option is fitted to the machine then pressing PLAY+FF+REW simultaneously will switch on the chase synchroniser (according to the selected mode see menus). In this mode all three LEDS will flash during synchronisation and will light permanently when the machine is locked.

14. **FAST FORWARD**



The FF key will put the transport into the fast forward wind mode, the speed of which is carefully controlled, meaning that the winding speed will slow down before the end of the tape is reached (Only operational with 5" reels). The winding speed in m/s can be set in the OTHERSET MENU to allow library winding of tapes if required.

SKIP FORWARD ONE TAKE



If EXE + FF key is pressed then the machine will jump to the next take (Skip forward 1 take). This feature will only operate if the tape is formatted with the directory mode ON. (see DIRECTORIES in chapter 3).

15. **REWIND**



The REW key will put the machine into the rapid rewind mode, the speed of which is carefully controlled, meaning that the winding speed will slow down before the end of the tape is reached (Only operational with 5" reels). The rewind speed in m/s can be set in the OTHERSET MENU to allow library winding of tapes if required.

SKIP BACK ONE TAKE

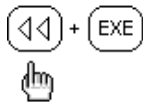

If the EXE key is held down while the REW key is pressed then the machine will jump back to the previous take (Skip backwards 1 take). This feature will only operate if the tape is formatted with the directory mode ON. (see DIRECTORIES in chapter 3).

NOTE:

The leds above each of the main function buttons will flash when the key is pressed, until the selected function is actually activated. For example if STOP is pressed during rapid rewind then the STOP led will flash while the machine comes to a complete stand-still.

16. **RIGHT ARROW**



This is the key used for moving horizontally to the right through the menus on the LCD display when in the MENU mode. (see MENU's chapter 3). When the end of a horizontal line is reached it returns to the start of the particular line.

ESCAPE FEATURE

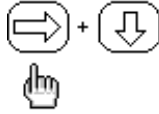

When pressed at the same time as the DOWN arrow the ESC (Escape) function is operated which will return to the top of the menu tree (ECC, TC, REMAIN etc.) display, or will act as a "NO" reply to a selection as opposed to EXE (Execute) for a "YES" reply.

17. **DOWN ARROW**



This is the "scroll" key and is used for passing vertically through the menus and from one choice to the next in a specified menu on the LCD display. When the last choice is reached when scrolling, then it will return to the first.

18. **EXE KEY**



The EXE key executes either choices made in the MENU mode (which are written in capital letters on the display) (See menu's) or can also be used to select the second functions written above the main function keys, it acts as a sort of "shift" key. Each of these secondary functions are described along with the description for each specific key. The DIL switch #2 on the direct amplifier inside the machine can be set to ON and this will disable the operation of the EXE key to avoid accidental changes to the settings of the machine.

If a second "alternative" display has been selected in the menu then it will be displayed whenever the EXE key is held down.

19. **LCD DISPLAY**

This is a 14 segment 8 digit back lit LCD display, permitting alpha-numeric indication of a large quantity of different information and allowing internal settings of the machine to be made in the MENU mode. In normal operation it will indicate either counter roller, time code (if ND-TC option is fitted), absolute time, take number or remaining tape. It is also used to display the internal STATUS of the machine. The display will be illuminated if the illumination switch 4 is put in the moon (night) position. The sign " ' " is used between some of the digits to indicate various modes of the machine (see time code). Any feature written in CAPITAL LETTERS on the display can be EXECuted. If small letters are used this is an intermediary step and cannot be executed as a feature. Example: "Set Gen." Cannot be executed but "REC.RUN" can be.

20. **POWER BUTTON**

The POWER button is the main power ON / OFF selector for the NAGRA-D. In the OFF mode none of the internal circuits of the machine are powered. When the machine is switched on then all the electronic circuits are powered, level adjustment and monitoring are possible.

Pressing the power switch while holding the modulometer selection switch 5 to the RESET HOLD position will perform a COMPLETE RESET of the machine, and the power will be turned off. This is similar to a CTRL + ALT + DEL on a PC.

NOTE: The machine must be switched ON prior to charging the internal battery, as it is the microprocessor of the machine that controls the charging current to the battery, and it therefore cannot charge the internal battery if the machine is switched OFF.

21. **BATT LED**

Under normal operating conditions the BATT led is alight if the internal battery is being consumed. The led will be OFF whenever external power is supplied. When the charge of the internal battery falls below 11V then the led will flash. When the battery reserve indication (see MENU'S) falls below 20% the batt led will start to flash slowly to warn the operator that the reserve is getting low. When the internal battery voltage drops below 10V then the LED will start to flash rapidly. At the same time an audible beep will be heard in both the headphones and from the machine itself, giving the indication that the machine will stop operating in 15 seconds. If the external charger is connected before the machine actually stops, the beep will immediately stop, however the led will continue to flash until the charger has supplied enough power for the battery voltage to climb above 10 V again. More accurate indication of the amount of power reserve left, can be seen in the menu mode. When selected to the display then the display will read bat. XX% and this indicates the % reserve in the battery. (see MENU'S)

LED OFF	Normal operation when external power supply is connected.
LED ON	Normal operation when using the internal battery.
Slow Flashing	Internal battery below 20%
Fast Flashing	Internal battery below 10V

22. **ALARM LED**

The ALARM led indicates when there is an error either internally within the machine or if the operator tries to operate a function incorrectly. (i.e. trying to reference the machine to the AES input signal when no cable is connected). If it is flashing but the machine appears to be operating normally then check the setting of the reference selection in the menu mode.

23. **AUDIO CHANNEL LOCK OUT SWITCHES**

These two switches are the LOCK-OUT selectors for the channels 1+2 and 3+4 respectively and are used to determine which audio channels will be recorded. The audio channels cannot be individually locked-out due to the shuffling and the layout of the information recorded on the tape. If the machine is put into the record mode and all channels (including TC and CUE) are in SAFE and the edit selector is in the INS position then the machine will stay in the stopped mode and the led above the record key will flash. These switches need to be set manually if a MIRROR COPY of a tape is being made between two NAGRA-Ds.

24. **CUE CHANNEL LOCK OUT**

This is the LOCK-OUT for the CUE track, which completely inhibits the recording of the cue track. Playback of previously recorded CUE information is unaffected by this switch. The CUE track should not be recorded in the INSERT mode, as crosstalk within the longitudinal head will disturb the reading of the control track. If INSERT editing is being made on the audio channels, then the CUE switch must be in the SAFE position.

25. **TIME CODE CHANNEL LOCK OUT**

This is the LOCK-OUT for the TC, which inhibits the recording on the time code track.

Playback and use of previously recorded time code is not affected by this switch. Time code must not be recorded in the INS position, as cross-talk in the head will disturb the reading of the control track. If INS editing is being made then the time code lock-out switch must be in the SAFE position.

This switch is only operational if the machine is equipped with the internal time code option.

26. **EDIT MODE SELECTOR**

This is the INSERT / ASSEMBLE switch used to determine the type of recording being performed. The insert position is used to record on a tape already containing a control track. Assemble mode is to be used on a new tape. (this could be considered as a lock out for the control track recording). If this switch is in the ASS position, and only one pair of audio channels is in the READY mode then when the machine is put into record, then the REC leds of the two channels in SAFE mode will flash to indicate that they are in fact being erased. **When the switch is in the ASS position then the full track erase head is activated, and previous recordings will be erased.**

27. **CAL LED**

This led lights when the fader is in its central calibrated position. This is the only position that the fader should be in order to guarantee that the full dynamic range of the machine is being used.

During playback, these leds will only be alight if the potentiometers were in the CAL position during the initial recording process.

28. **OVERLOAD LEDS**

The overload led will flash when an input level of the A/D converters reaches saturation. This value is different for machines fitted with 18 bit and 20 bit converters. The correct overload point is a factory set hardware option setting made on the lap top PC depending on the A/D converters installed. For the 20 bit A/D converter the led will flash when -1.16 dB is reached. For 18 bit converters this overload occurs at -0.013 dB. These different figures are due to the overload characteristics of the A/D converters. In previous versions of software (below V 2.X) the value was set at -1.16 for both types of converters. If the machine is set to AES input then the overload LEDS are set to light at 0 dB automatically. The overload led will indicate even if one sample goes above the specified limits.

FRONT FACE

1. PHASE SELECTOR

The PHASE switch (one for each channel) is a two position selector and allows inversion of the phase for each of the inputs individually. The position of this switch is recorded on the tape and can be altered during playback if desired (see MENU's), as this does not actually invert the phase of the inputs but rather a digital calculation.

2. FILTER SWITCH

The L.F. CUT switch is a three position filter on the direct amplifier, and allows the selection of either FLAT, LFA or Speech filters for each input. (similar to the filters on portable analogue NAGRA recorders).

Below are the filter curves (audio precision) corresponding to the three positions of the filter

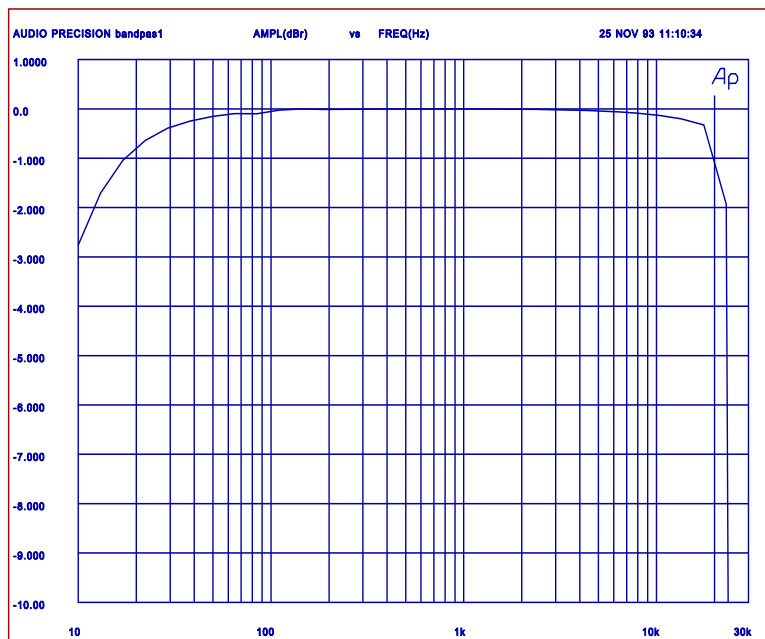

FLAT filter response curve

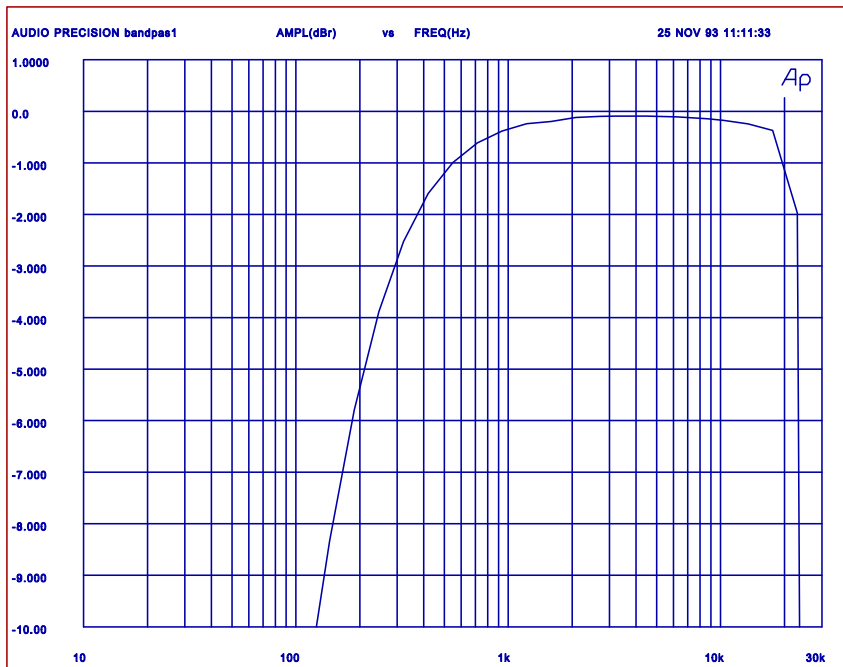

Speech filter curve

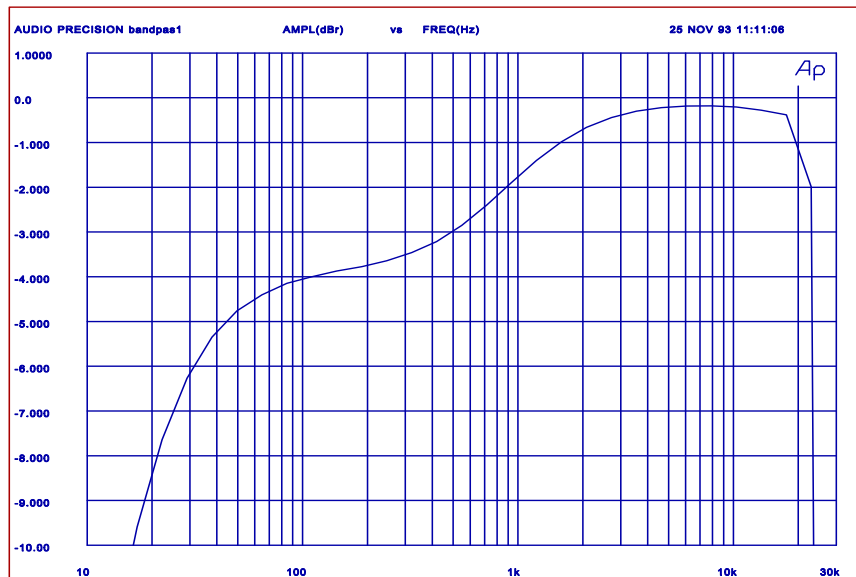

LFA filter curve

LEFT-HAND SIDE PANEL

1. MICROPHONE POWERING SELECTORS

These four position input selection switches allow the selection of the microphone powering for each microphone input individually as well as the selection of the LINE position. The possible selections are Line, +12V "T" power, +12V phantom and +48V phantom. The input selector must be in the LINE position if an analogue line input or a dynamic microphone is to be used. The sensitivity of these inputs is made using the outer ring (8) of the co-axial potentiometers on the main control panel. If a line input is fed to the machine either external attenuators (ND-LIA #10550) need to be fitted or the (ND-IL #10323) line input optional circuit needs to be installed inside the machine.

2. ANALOGUE INPUT CONNECTORS

These are the four XLR (female) analogue inputs. They are the connectors used both for microphones or line inputs, the sensitivity of these inputs is adjusted using the outer ring of the co-axial potentiometers on the main control panel.

The connection of these connectors is as follows:

Pin 1 = Earth (ground)

Pin 2 = Audio Hi

Pin 3 = Audio Lo

3. DIGITAL INPUT CONNECTORS

These are the two XLR (female) digital inputs to the NAGRA-D. They are to be used whenever the machine is connected to another piece of equipment communicating on the AES bus. The selection of the inputs to digital mode, as well as the reference frequency is made in the menu mode. (see MENUS)

4. VIDEO SYNC CONNECTOR

The BNC type connector is the input signal for the video reference. This is a standard "House SYNC" input used for synchronising the machine. This connector is internally terminated with a 75 Ohm load. This input will accept PAL, NTSC and NTSC 60 video references.

5. TIME CODE IN / OUT

The 5 pin LEMO connector is the time code IN / OUT connector. (as on the ARES-C, NAGRA T-AUDIO, IV-STC and VPR-5). This is used to feed an external time code to the machine as well as to read the played back time code. Jam syncing of other devices is done through this connector.

6. EXTENSION - EXTERNAL CONNECTION PORT

This 15 pole miniature D-type connector has many functions, and is the principle connection point for external accessories. The ND-CM CUE microphone is connected here and allows commentary to be recorded on the cue track. It can also be used to supply an external sync signal to the machine as a reference, it also has time code IN / OUT connections. The pinning of this connector is as follows:

Pin N°	Connection
1	Cue track IN +ve
2	GND
3	Cue track IN -ve
4	Sync OUT
5	Not presently used
6	External Sync reference IN
7	-10V FM for ND-CM cue microphone
8	ND-CM Cue microphone IN
9	-10 Cue mic
10	Unused
11	TC IN +ve
12	TC IN -ve
13	GND
14	TC OUT +ve
15	TC OUT -ve

7. RS 422 CONNECTOR

This is a standard 9-pin RS 422 symmetrical 0 to 5 V RS 422 serial communication port for connection to the external world. This connector can be used to communicate with external interfaces allowing communication with editors etc. It is also used for connection to a PC. When connected to the PC access to all the functions of the machine are available. In order for communication to be made between the NAGRA-D and a PC then the NADCOM software must be installed on the PC. The NAGRA-D must be in the SLAVE position in the menu in order to operate with the NADCOM software.

This connector is also used when remote control of another machine is being made from the NAGRA-D.

NOTE: A "lap-top" style PC is not always fitted with an RS 422 port. A converter RS 232 / RS 422 must in this case be fitted to the cable to allow the communication. (ND-PCA # 10540)

RIGHT-HAND SIDE PANEL

1. POWER CONNECTOR

The three pole LEMO style POWER connector is the connection for the ND-CCC (Current Controlled Charger) or ND-EPC (External DC/DC converter), which is used to charge the internal battery pack. The charge current for the internal battery is controlled in the charger by the machine itself, or an external battery if the machine is equipped with the ND-AP option. and therefore under NO CIRCUMSTANCES must any charger or power supply other than the ND-CCC or ND-EPC be connected to this point. The machine must be ON in order to charge the internal battery. (see "Powering the NAGRA-D" in chapter 1 of this manual). The internal battery will only charge in the LOAD or PARK positions.

2. HEADPHONE CONNECTORS

Two 1/4" standard stereo headphone jack connectors. The outputs of which are governed by the positions of the headphones selector switches on the main control panel. The two connectors are in parallel and it is therefore not possible to adjust the levels of the two outputs individually. The level of the headphone outputs is controlled using the potentiometer #3.

3. HEADPHONE LEVEL CONTROL

On early NAGRA-D machines this is the 5 position stepped headphone output level control, which controls the headphone output level to each socket simultaneously. On more recent machines this switch has been replaced by a potentiometer.

4. DIGITAL OUTPUT CONNECTORS

These are the two XLR (male) digital outputs from the NAGRA-D. These are used for the AES bus connection to other equipment. Each of these two connectors carries one AES bus (stereo), one for channels 1+2 and the other for channels 3+4. If the machine is in the 96kHz operation then the 1+2 connector corresponds to the left channel and the 3+4 connector to the right channel.

5. ANALOGUE AUDIO OUTPUT CONNECTORS

These are the four XLR (male) analogue outputs. They are transformerless 3.1 V (Zout = 50 Ohms). The output level on these connectors can be modified using the fader potentiometers for the respective channel, assuming the FADER SRC command has been set to the MANUAL position in the FADER ASSIGN menu mode.

BEWARE: If the 4 audio outputs are being mixed down using an external mixer, be sure that the mixer is not set to +48V phantom, as feeding this to the outputs of the NAGRA-D will blow the output chips.

The connection of the analogue output connectors is as follows:

Pin 1 = Earth (ground)
Pin 2 = Audio Hi
Pin 3 = Audio Lo

6. CARRYING HANDLE

The carrying handle of the machine can also be used to incline the machine during "table-top" operation by sliding it to the rear of its travel. If the ND-SET 7" reels cover is fitted then the carrying handle should be removed and turned in such a way that the machine is suspended from the rear when being carried.

CHAPTER 3

OPERATING THE NAGRA-D

Power On.....	34
Loading A Tape	34
Menu Mode.....	36
Display Selection	39
Time Code Selection	41
Battery Reserve Display	46
Inputs Selection	47
Sampling Frequency Selection	48
Reference Frequency Selection	49
Tape Speed Selection	51
Directories.....	52
Other Settings.....	53
Fader Pot Selections	58
Template.....	59
Copy.....	60
Alpha-Numeric Listing Of Menu Displays	61
Cue Track	65
Using The Cue Track.....	65
Using The Nd-Cm Cue Microphone.....	65
Monitoring On Headphones.....	66
Edit Mode (Search).....	66
Microphone Inputs	68
Recording	72
Recording With Microphones.....	72
Recording A Line Input Signal	73
Using The Nd-II Line Input Circuit Option	73
Recording A Digital Signal.....	73
Playing Back A Recorded Tape.....	74
Making A Copy Of A Nagra-D Tape	74
Copy To Another Digital Machine.....	74
Mirror Copy Of A Nagra-D Tape To Another Nagra-D.....	75
Explanation Of The Procedure For The Copy Function.....	75
Copy Channels 1 + 2 From The Nagra-D Onto Channels 3 + 4.....	77
Removing The Internal Battery Pack.....	78
Tape Directories	79
What Is In A Directory ?.....	80
Tapes Without Directories	81
Turning On/Off The Directory Mode.....	81
Data (And Setting Of) For The Directory	81
Directories And Half Speed Operation.....	81
Operation Of The Directories.....	81
Making A Standard Recording.....	81
Using The Rec + Rew Command.....	83
Playing Back A Tape With A Directory	83
Working With Tapes "Tail Out"	83
Updating Of A Directory.....	83
Skip Features.....	85
Insert And Assemble.....	85
Tracking.....	86
Adjusting Tracking At Half-Speed.....	88
Display Messages.....	89

POWER ON

To switch on the NAGRA-D simply press the black POWER button on the left-hand corner of the main control panel. The display will initially indicate NAGRA-D (or personal name if programmed) followed by a scroll through the present settings of the recorder and will stop on the previously selected display, the machine is now ready to accept a tape.

If the machine is powered up, and the display initially shows NAGRA-D and then immediately goes off, internal battery is probably flat. If the machine will not power up at all, this indicates that the internal battery is so flat that there is not enough reserve to power the microprocessor which detects that the charger is connected. If this is the case then connect the external charger and leave the machine for about 15 minutes and then try again. This will only occur after long periods of storage. Do not try to turn on the machine during this 15 minute period as this will drain the build up of charge.

If the internal battery of the machine has been replaced (while the machine was OFF) or it has become completely flat, then when the power button is pressed the display will indicate "Mem Lost". Five beeps will be heard, which indicates that all the USER settings and any directories that were previously in the internal memory have been lost.

If version 2.xx software has been installed then the first time the machine is powered up a password needs to be entered (this should be done by your nearest dealer when the eprom is installed). Each machine has its own 8 digit password to be entered on the display. This will only occur on the first power-up. Please contact your nearest dealer if you need the password.

LOADING A TAPE

All forms of digital tape are fragile, firstly because they are very thin (approx. 30 μm) and secondly they are delicate with respect to moisture. Avoid touching the tape as much as possible.

NOTE: The Error correction of the NAGRA-D is powerful enough to correct errors caused by touching the tape, but as a general rule it is not recommended.

Place a full reel of tape on the left-hand reel holder, and with the tape coming off the left-hand side of the reel. Press the POWER button of the machine. Gently pull the available end of the tape and guide it around the right-hand side of the outer tape roller and then around the tension roller. You will notice a slight back tension once it passes the tension roller. Continue to pull the tape across in front of the longitudinal headblock, and then the scanner, following the black line of the tape path printed on the deck plate of the machine. Pass around the right-hand tension roller and then secure it onto the take up reel in the same way as you would with a normal $\frac{1}{4}$ " tape according to the drawing below.

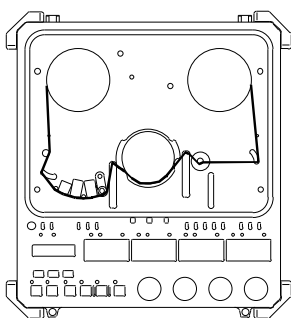

The machine will detect this operation, and automatically take up the tape providing that during this time both tension rollers leave their end-stop position, and will then start to look for a directory on the tape, otherwise press STOP in order to initiate the search mode. (see directories).

If a directory is detected it will be automatically read. If no directory is detected but the tape has previously been recorded, the display will indicate "No Dir" and will stop at the beginning of the recording. If it is a new tape that has never been used, then the operator will be asked (on the display) whether the tape is to be formatted by displaying "FORMAT ?". "EXE" will be accepted as YES and "ESC" will be accepted as NO to this request. If EXE is pressed then the machine will immediately format the tape which takes a few seconds. If ESC is pressed then the machine will automatically turn the directory mode OFF.

The tape is now loaded and ready to be used.

If a tape has been left "tail out" and the directory mode is ON then when the tape is loaded onto the machine, the full reel will be placed on the right-hand reel holder and the operator winds several turns onto the left-hand reel and then presses the REW key. The machine will then go to the start of the tape and automatically look for the directory.

MENU MODE

The NAGRA-D incorporates a system of menus similar to the "tree" of directories and sub-directories on the hard disk of a PC. The functions that are available via the menu mode are not operations that need to be done frequently during normal use of the machine in the field. The menu viewing and modification is made using three keys, "DOWN" (indicated by a vertical downward arrow), "RIGHT" (indicated by a right facing arrow) and the "EXE" (execute) key.



Used to move RIGHT through the menu mode



Used to move DOWN through the menu mode



Used to EXECUTE a desired function or to confirm a selection.

Using these keys and the display, all the operating modes of the machine can be user accessed, and verified at any time. The DOWN and RIGHT arrow keys will not modify any of the settings within the machine. These are used simply to move around in the menus and once the desired selection to be modified is on the display then the EXE key is used to make the modification. When the EXE key has been pressed a "beep" will be heard (either internally or on the headphones depending on the present setting of the beep function) to indicate that the selection has been correctly accepted. The display will then generally return to the initial display, except when a second selection is necessary. The display will jump directly to this selection. For example, if the inputs 1+2 are selected to digital, then when the EXE key is pressed, the display will immediately go to the Inputs 3 + 4 to allow the selection of the other pair of inputs to avoid the user needing to go through all the menus again.

If the display remains on the selected choice after EXE has been pressed, this indicates that the feature has NOT been executed for some reason. This could be because it is not an executable function or that the machine will not allow it to be selected due to other settings. For example, if the machine is in 96 kHz operation and the user tries to select one of the pairs of inputs to analog, then the setting will not be accepted.

Pressing ESC will exit the menu mode and the display will return to the normal display mode. The DIL switch number 2 inside the deck plate of the machine can be used to prevent the EXE function from operating. When this switch is in the ON position the EXE function will be ignored. This can be used to prevent accidental changing of the internal menu settings.

When a function is executed in the menu mode, the display will return to the first line of the feature being chosen. This prevents the user having to go through all the menu positions each time a feature is to be selected. To return to the initial display press "ESC".

NOTE: When the machine is powered up, the presently selected settings of the machine will be indicated on the LCD display with the scroll function. If at any time the RESET HOLD switch for the meters is activated the menu's will also scroll through the presently selected choices. All settings of the machine are memorized when the power is switched off, as long as there is sufficient power in the internal battery. If however the internal battery becomes flat, then when the machine is powered up the next time the display will indicate "MEM LOST" and will scroll through its factory default settings, which, unless modified by the user in the WAKE UP menu are as follows:

- | | |
|----------|---|
| 48 kHz | - Sampling frequency |
| MASTER | - NAGRA-D is locked to internal crystals |
| 12 ANA | - Channels 1 + 2 are set to ANALOG |
| 34 ANA | - Channels 3 + 4 are set to ANALOG |
| 4 TRACK | - Tape speed is in the 4 channel mode (99.4 mm/s) |
| DIR. ON | - Tape directory mode is ON |
| Bat xx % | - Current reserve in the internal battery. |

If the RESET HOLD is activated a second time while the menu is scrolling then the time code and synchronizer settings will be shown assuming the machine is equipped with the internal time code option.

25 f.p.s	Frame rate of internal generator
INT.GEN.	Recording source for time code is the internal generator
FREE RUN	The generator is in the free running mode
SYNC	The chase synchroniser is in the SYNC mode.
REF tc	The reference for the internal synchroniser is set to time code
VAR.CLK.	The time code clock reference is in the VARIABLE mode.

In order to select the MENU mode to the display, simply press RIGHT arrow or the DOWN arrow key, and the display will indicate the display mode or INPUTS. All the other menus will be explained below. In order to get out of the MENU mode press the DOWN and RIGHT arrows simultaneously (escape) and the display will return to the initial display. When the machine is powered up the display will show the last display mode selected before power down (time code, counter, absolute time, track number etc.)

MENU TREE FOR NAGRA-D SOFTWARE VERSION 2.10

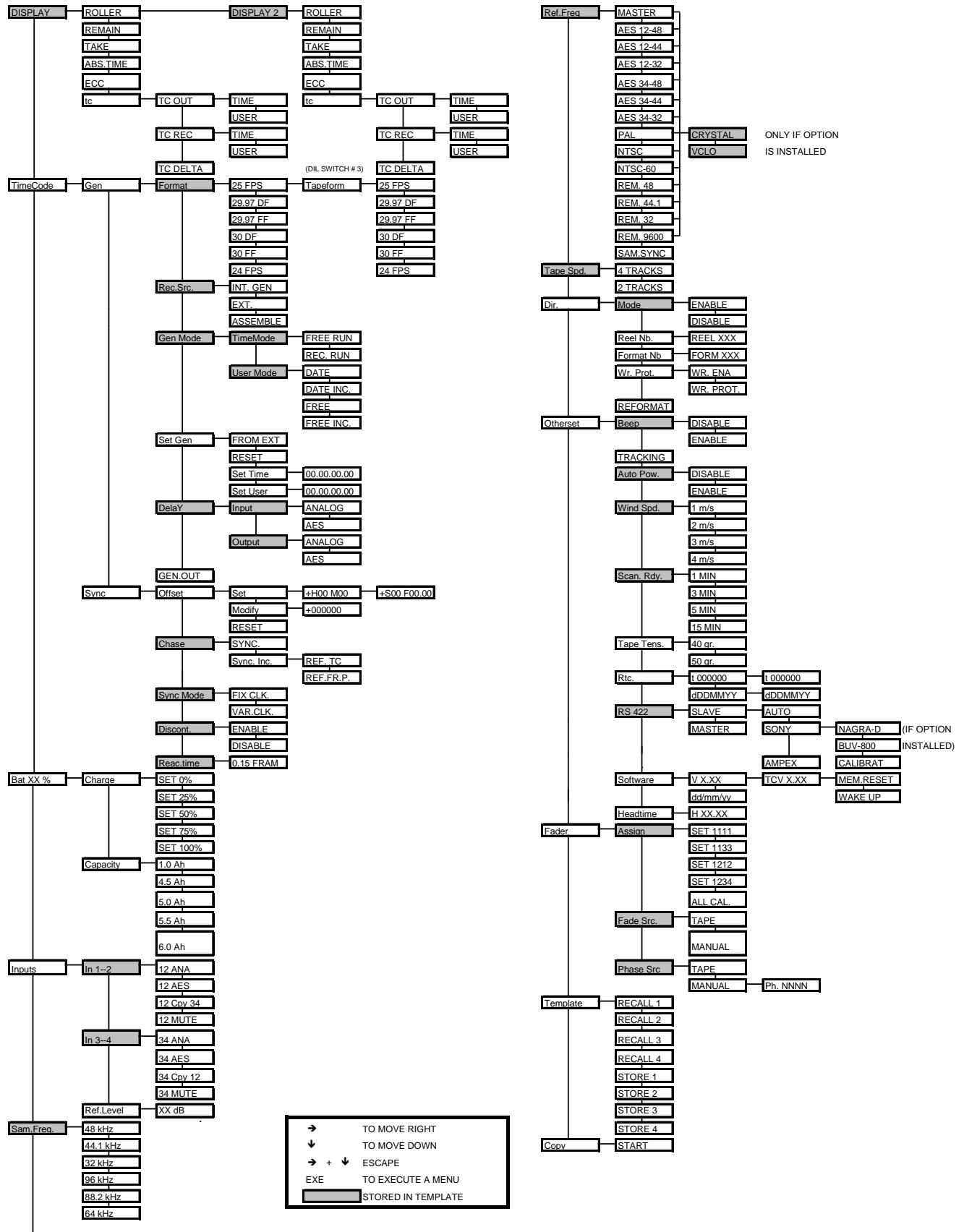

DISPLAY SELECTION

This is the first line of the status display, and will always indicate the preselected mode. If the right arrow key is pressed then the user can select the different display modes possible, the down arrow is used to scroll through the possible options. This selection is the one that will automatically be displayed when the machine is switched on or after a scrolling of the selected settings has been completed. The possible selections are ROLLER, REMAIN, TAKE, ABS. TIME, ECC and TC (the last one only if ND-TC option is installed). Please note that the word DISPLAY is never indicated, the display at the top of the menu tree is the currently selected choice. A second display can be selected by moving to the right and pressing the EXE key.

This means that the alternative display will be shown during normal operation whenever EXE is pressed. For example, if the first (principle) display is set to time code, then ECC could be selected as a second display and glanced at as desired upon pressing EXE.

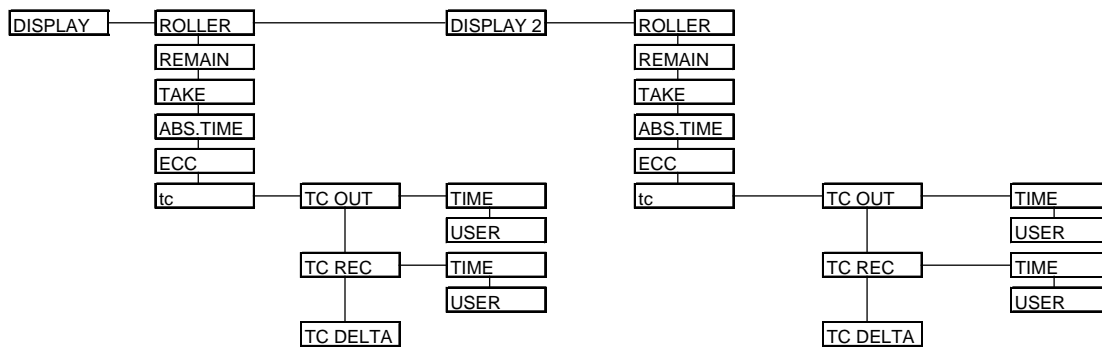

ROLLER This shows the tape timer counter roller which is indicated in hours, minutes and seconds, and is driven by the left-hand tension roller. The indication of the counter roller depends on the sampling frequency selected, and will adjust accordingly if the sampling frequency of the machine is changed.

REMAIN This position allows the operator to look at the remaining tape on the supply reel indicated in hours and minutes. This is calculated by the machine whenever it is in motion. The calculation is made by regarding the relative speeds of the reel motors. Therefore it takes several rotations of the reel motors to give an accurate reading. While the calculation is being made, the display will only indicate "- - -". It should be noted that the calculation is only accurate if the same reels are being used on both reel motors. If one is a 5" and the other a 7" then the reading will be wrong. Once the calculation is made, the display will indicate the remaining tape (R) in Hours and Minutes "R h.mm". The remaining time is calculated based on the current sampling frequency selected. It will automatically change if the sampling frequency is changed.

TAKE When this position is selected, the display will indicate the "TAKE" number followed by the time from the beginning of the present take which is indicated in h.mm.ss. The take number will automatically be incremented by "1" each time the machine is put into record mode. This display can be used when the machine is in all operational modes. This can also be done without dropping out of record by simply pressing the two buttons again to create a new take number. At nominal speed the take number will be indicated even if there is no directory on the tape.

- ABS. TIME** This is the ABSOLUTE TIME indication and will indicate the time in hours, minutes and seconds from the start of the tape. It is actually counted from the end of the directory. When this selection is chosen, then the current take number will also be displayed to the left of the absolute time. If the take number is greater than 99, then only minutes and seconds will be displayed. If in this case the absolute time is greater than 1 hour then the "Hours" digit of the absolute time will be replaced by a "+" sign.
- NOTE:** In the TAKE or ABS TIME displays, if the TAPE / EE selector is in the EE position during record, the time will be correct. However, it is updated by the counter roller during playback, and may not be exact.
- ECC** If ECC is selected then the indication is two pairs of numbers corresponding to the channels 1+2 and 3+4 respectively. This operates in both record and replay modes, and indicates from 0 to 99 the amount of errors being detected and corrected. If there is 1 or more errors that are not corrected then FA is indicated instead of the numbers.
- This FA stands for FATAL error. If the machine is in the half speed mode then the right-hand pair of digits will read FA permanently, as there are no tracks 3 + 4 recorded on the tape. If the HOLD MAX position of the level switch is selected the ECC display indication will act in the same manner as the level meters, showing the max ECC level reached up to the present point. This is reset by switching to RESET HOLD.
- During record, even if the selector is in the EE position, the errors indicated on the display are still those of the tape. At half speed if the machine is not equipped with read after write at half speed and this selector is in the EE position then the ECC display will be errors of the internal DSP rather than the tape, and logically will always show 00.Fa.
- TC** This position of the display is the access to the time code displays (if the machine is fitted with the ND-TC option). When moving to the right from this display the time code indications explained below are shown.
- TC OUT** If TC OUT is selected then the time code that is being fed to the Lemo connector output is displayed. In playback this will be the time code read from the tape. If GEN OUT is selected then this will be the internal generator. If the right arrow is pressed when TC OUT is on the display then the TIME will be displayed. If subsequently the down arrow is pressed, the USER bits information will be displayed. Pressing EXE will select the desired mode. (Note that these settings are only the OFF TAPE or GEN OUT information). When the machine is in playback, the off tape signal will be fed to the TC OUT and during record, the TC OUT display will be the signal being recorded.
- TC REC** If TC REC is chosen then the time code that is to be recorded onto the tape (either internal generator or external depending on the time code settings) is displayed. From this position the user may move to the right and then select either USER or TIME to be displayed, by pressing "EXE" for the desired selection.
- TC DELTA** This display is the dynamic difference between the external time code reference and the time code on the tape while the machine is in the chase synchronize mode.
- NOTE:** The time code selections mentioned above only appear if the NAGRA-D is fitted with the ND-TC option (#10370)
- DISPLAY 2** This position allows the selection of an additional display. When a second display is selected it can be displayed at any time by pressing the "EXE" key. For example, if the normal display is Time code, then the second display could be set to ECC which can be glanced at whenever necessary for as long as the EXE key is pressed.

TIME CODE SELECTION

This position allows the setting of the time code options of the machine. It permits the setting of the internal time code generator, for both TIME and USER data, as well as frame rate selection and the time code mode. It also allows the choice of the time code to be recorded, as well as access to the internal time code synchronizer features, including modes of operation as well as external references to be used. These displays will only be indicated if the machine is fitted with the ND-TC time code option. Scrolling display of the presently selected time code features can be made by pressing the RESET HOLD switch twice.

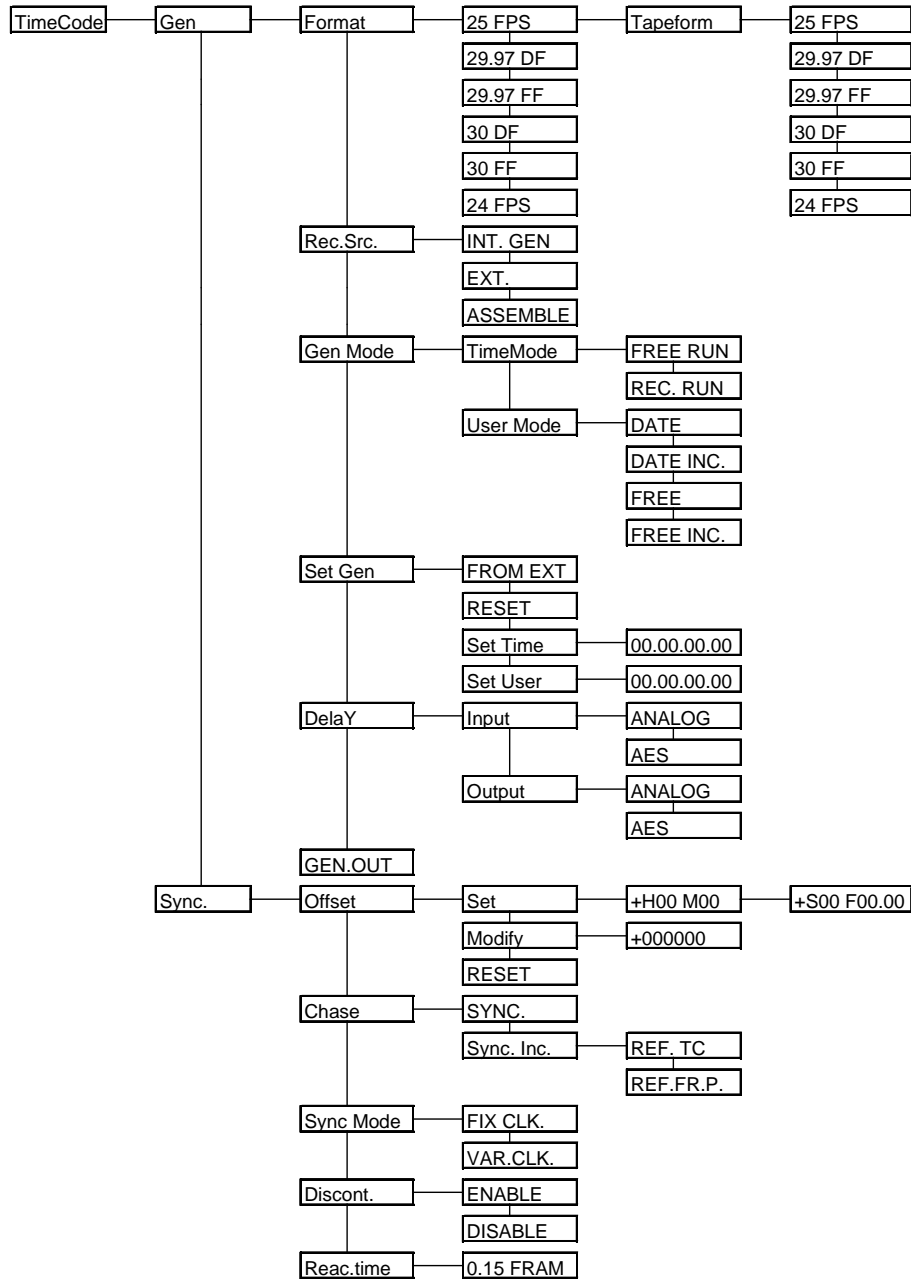

GEN When the right arrow is pressed from the TIME CODE position, access is given to all the internal generator features and hence "in the field" access to setting of all features concerning the internal time code generator.

If the down arrow is pressed from this point, the display will change to SYNC which allows access to all the settings of the internal time code synchronizer.

Pressing the right arrow from the GEN position will move to FORMAT allowing all the different operating modes and features of the internal generator to be set.

FORMAT When the right arrow is pressed from the GEN position the operator can select the frame rate of the internal time code generator. The internal time code generator can generate all presently used formats i.e. 24, 25, 29.97 and 30 (the latter two either with or without drop frame). The first value indicated is the presently selected choice. The default value, automatically selected if the memory has been lost, is 25 frames per second. Pressing the down arrow will scroll through the other possible choices in turn, which are selected by pressing "EXE". This choice is kept in memory as long as there is sufficient power in the internal battery, or permanently if it has been stored in a template.

TAPEFORM Moving to the right from the frame rate selection will give access to the tape format menu. This feature allows the machine to synchronize tapes that have a time code recorded on them that does not correspond to the external time code reference. (providing the DIL switch number 3 is in the ON position. If the DIL switch 3 is off then this menu will not appear).

What this allows, is for a tape that is for example 29.97 df to be synchronized to a 24 or 25 frame reference. All combinations of tape and reference formats can be used.

From the TAPEFORM display, pressing the right arrow will once again shows the list of frame rates available, as for the format. This can be set to the frame rate of the tape that is presently on the machine.

REC SRC If the down arrow is pressed from the FORMAT position the display will show REC.SRC. This is the time code source selection for the time code to be recorded on the tape. It can be set between INTernal GENerator, EXTernal or ASSEMBLE, by pressing the right arrow followed by the down arrow. If in the EXT position then an external longitudinal SMPTE/EBU time code must be fed to the time code LEMO connector on the left-hand side of the machine. Making this selection will not necessarily be indicated on the display - only if the correct DISPLAY selection has been made. If INT. GEN. is selected then the internal time code generator of the machine will be recorded.

If ASSEMBLE is selected then the recorder will make a seamless time code assemble when RECORD is activated. An assemble means that the time code from the tape will be read during the pre-roll period and then the time code will continue from the last number recorded on the tape.

There are some circumstances where this may cause confusion - for example a CRASH RECORD, (record on a blank piece of tape with no time code /control track existing before the record command). In this case it will record from the last time code read on the tape which has since been updated from the counter roller. However during normal operation it will assemble correctly. In the ASSEMBLE mode the FREE RUN / REC RUN modes of the internal generator will have no effect. The only point that should be remembered is that when making Assemble time code naturally the RTC of the machine will not change date at the correct time if the USER BITS are in DATE MODE and in REC RUN.

GEN MODE From this position, pressing the right arrow moves the display to the choice between TIME mode and USER mode. From the TIME MODE position the right arrow allows selection between FREE RUN and REC RUN by means of the down arrow. Free run means that the internal time code generator will run permanently according to the preselected frame rate. In the REC RUN position, it will only run when the machine is in the record mode, allowing continuous time code to be recorded. The TIME and USER mode settings are both remembered if they are stored in a template.

To avoid any problems during post production, if this mode has been selected please set the reaction time of the slave machines synchronizer to greater than 2 seconds. From the USER MODE position, pressing the right arrow allows access to the possible mode of the USER bits which can be either DATE or FREE. In the DATE position then the date in the DD.MM.YY.xx format must be used. In the FREE position then the user bits can be any value in HEX (0 to F). Both of these choices also have an INC feature meaning that the last two positions (xx) will automatically be incremented by "1" each time the machine is put into record, starting from 00 up to a maximum value of 99.

SET GEN This position allows access to the setting of the internal time code generator. Pressing the right arrow indicates FROM EXT meaning that the internal generator will be set from the external time code on the time code connector, if the "EXE" key is pressed. From this position pressing the down arrow will indicate SET TIME, from where, if the right arrow is pressed the display will indicate 00.00.00.00 and the left most digit will flash. By pressing the arrow keys modification of the values of each digit is allowed. The down arrow will increment the value and the right arrow will move the flashing digit to the right. Press EXE to store the new values into the internal generator. Pressing the down arrow from the SET TIME position will move the display to the SET USER position, and in the same manner as for the time code, the values of the USER BITS can be set. If the generator is in the DATE user bits mode then the numbers entered must correspond to the DD.MM.YY.xx format. If they are in the FREE mode then any value from 0 to F (hex) can be entered in each position. The RESET position allows the operator to immediately set the TIME portion of the time code to zero without affecting the USER information. There is also a "short-cut" to reset the generator quickly. Pressing EXE when "Time code" is on the display will jump immediately to the reset TC position. Press EXE to reset the time portion of the generator.

DELAY This position allows the user to select the reference point for the time code of the NAGRA-D. The selection is necessary as there is a very small difference in the time code values on the inputs and outputs of the machine and also between digital and analog signals, due to the different processing time between digital and analog signals. This delay is only a matter of a couple of bits, but in very accurate synchronizing applications it may be necessary to take these delays into account. If these selections are not made then there may be problems during synchronization.

INPUT Pressing the right arrow from the DELAY position moves the display to the INPUT position. If EXE is now pressed this means that the time code is referenced to the sound at the input of the machine, and is the mode that should be used during recording. Pressing the right arrow allows the user to then select either ANALOG or AES inputs depending on the inputs being used for the recording. If the user is using one pair of inputs in the analog mode and the other pair in the digital mode at the same time then he must decide which of the two is to be the reference, the other will then have a small delay. The input delay selection can be stored in a template.

OUTPUT Pressing the down arrow from the DELAY position moves the display to the OUTPUT position. This means that the time code is referenced to the sound on the output of the machine, and is the mode that should be used during playback and synchronization of the machine. Pressing the right arrow from OUTPUT allows the user to select either ANALOG or AES outputs depending on the outputs being used. If the user is using one pair of outputs in the analog mode and the other pair in the digital mode at the same time then he must decide which of the two is to be the reference, the other will then have a small delay. The output delay selection can be stored in a template.

GEN OUT Pressing EXE when GEN OUT is on the display will feed the internal generator to the external time code connector on the left-hand side of the machine. Thus the internal time code generator of the NAGRA-D can be used as a master clock to set any external device. This mode is only operational until another function is activated. Thus if for example the PLAY key is pressed then the signal on the time code connector will automatically switch to the time code playback signal. However this position is remembered when the machine is switched OFF, It will only be canceled when another transport function such as PLAY is pressed.

SYNC This is the start of the menu selections affecting the internal time code chase synchronizer of the machine. The internal synchronizer of the NAGRA-D is activated by pressing the PLAY + FF + REW keys simultaneously, and the synchronizer will synchronize according to the settings below. If the right arrow is pressed then the display will change to OFFSET.

OFFSET The OFFSET position allows the operator to have access to the time code offset between the "off tape" time code and the time code reference. Pressing the right arrow key moves to the setting mode and pressing the down arrow moves to the next synchronizer option, which is SYNC MODE, the operating mode of the CHASE feature. If the right arrow is pressed then the display will show SET meaning that the operator has the possibility to press the right arrow again and set the offset in hours and minutes, and then automatically the seconds, frames and bits afterwards, upon pressing "EXE". This has to be done on two different display screens as there are only eight digits and it is not possible to indicate the hours portion and the bits of OFFSET at the same time. Values are entered using the down arrow to increment the value of the current digit and the right arrow to move to the next digit. Once the offset has been set, if the "EXE" key is pressed then this offset will be stored in the offset register. If the down arrow is pressed from the SET position the display will change to MODIFY and moving to the right now will display the current offset (in secs, frames and bits) and will also activate the N°4 FADE potentiometer allowing the offset to be changed "on the fly". In this mode the offset will change UP or DOWN depending on the rotational movement of the #4 pot. There are three angular positions STOP, SLOW modification and FAST modification depending on the angle through which the pot is turned. If the down arrow is pressed from the MODIFY position, then the display will show RESET. If EXE is pressed then the offset will be reset to 0.

CHASE The CHASE position allows the selection of the manner of synchronization of the NAGRA-D. There are two different possibilities of synchronization. The first being simply SYNC meaning that the time code on the tape corresponds exactly to that of the external reference, the second being SYNC INC (Incremental) meaning that there is an unknown time code offset between the external reference and the time code on the tape. When the machine is put into the SYNC INC mode (by pressing PLAY + FF + REW simultaneously) the offset between the two time codes at that exact moment is stored in the offset register automatically. From the SYNC INC position the right arrow may be pressed and the display will indicate the choice of external reference for the time code synchronizer.

The choices are REF TC (reference time code) or REF.FR.P. (reference frame pulse). The reference frame pulse allows the synchronizer to synchronize the time code on tape with an external video reference. In all cases, an external reference, of one form or another, must be fed to the machine for any mode of synchronization to be accomplished. The possible selections of the CHASE mode can be stored in a template.

When under the SONY 9-pin control it is the editor that performs the synchronisation function not the NAGRA-D. The difference between REF TC and REF FR P. is in the interpretation of the PLAY command: for a more ample explanation of this selection please refer to "Settings" at the end of chapter 4 in this manual.

REF TC	- NORMAL PLAYBACK
REF FR. P.	- PLAY LOCKED TO VIDEO

- SYNCMODE** The NAGRA-D has two possible clock references that affect the operation of the synchronizer.
- FIX CLK** In the FIX CLK mode the machine will always follow the external reference. Once the machine is in the LOCKED state the internal synchroniser will no longer influence the transport and the transport speed is controlled entirely by the reference frequency (REF FREQ menu). If however the synchroniser of the NAGRA-D sees an error of more than 1 frame, it will re-engage itself to correct the synchronisation error. **This is the recommended operating mode.**
- VAR CLK** This mode is designed to allow the machine, using the internal synchroniser, to follow an external reference that is not the same as the REF FREQ selected in the manu. This setting allows the internal synchroniser to modify the internal clocks in such a way as to follow this REF FREQ (for example NTSC / NTSC 60). In this mode the digital outputs are not available and the quality of the analogue outputs may be slightly degraded. Such a situation arises when the tape has 30FF time code and the external reference is NTSC (59.94). The machine will slow the tape down to 29.97 FPS.
- NOTE:** When slowing down the tape (from 60 to 59.94 (30 fps to 29.97 fps)) the AES outputs of the machine will not be stable enough to make a digital copy UNLESS the machine is fitted with the VCLO option (10200). Machines with serial number lower than 1000600 may need a modification on the Encoder circuit before the option can be installed.
- DISCONT** This position allows the operator to switch ON or OFF the discontinuity handling feature of the internal synchronizer. This function is only operational when the machine is at nominal speed and in the LOCKED state. It is used to allow the machine to cross over discontinuities in the time code smoothly by either adding or subtracting the jumps from the offset register automatically. The operation of this feature can be stored in a template.
- REACTIME** This feature gives access to the reaction time of the internal synchronizer. This is the number of incorrect consecutive frames that will be accepted during the SYNC mode before the NAGRA-D will drop out of the LOCKED state. The default setting for this is 15 frames, and can be set to any value from 15 to 999 frames (33 seconds at 30 fps or 42 seconds at 24 fps). This is used to handle time code drop-outs during post production. The reaction time of the internal synchronizer can be stored in a template.

BATTERY RESERVE DISPLAY

BAT XX % is the display indicated when the down arrow is pressed from the TIME CODE position. This indicates in percentage the amount of power left in the internal battery. When an internal battery is removed and replaced, the machine will assume it is full and set the display to 100% unless otherwise programmed by the user.

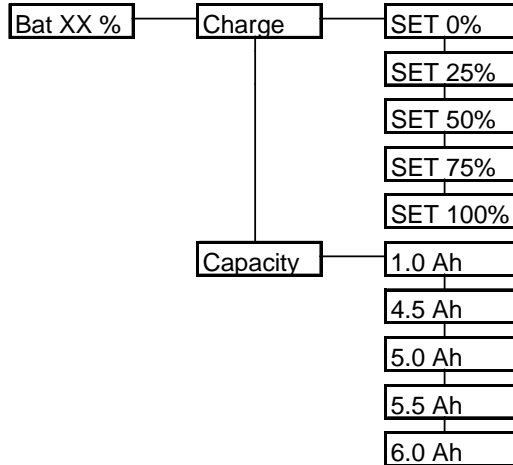

CHARGE

From this position pressing the right arrow will indicate SET XX % (XX being the known battery reserve in %) this can be set to 0, 25, 50, 75 or 100 % by pressing the down arrow. When the correct value is displayed press the EXE key and the displayed value is automatically stored. Naturally if the operator sets this value incorrectly, for example to 75% when in fact the battery is only at 25%, when the charger is connected to the machine, the internal battery will charge until the display shows 100% but actually the battery itself will only be at 50%. In this event, during use of the machine the BATT warning led will start to flash once the battery drops to 50% on the display. This feature is simply a timing function which approximates the charge state of the battery. As the internal battery pack of the NAGRA-D is a nickel cadmium and has no electronics inside it is impossible for the machine to determine the amount of reserve that a battery has. Thus if the setting is done incorrectly by the operator then the battery reserve indication will never be right.

If the battery is set to anything other than 100% then the ND-CCC / ND-EPC will automatically be instructed to charge it at the 400 mA rate for an amount of time that should bring it to 100%

NOTE: This display is only a "timer" not an accurate indication of the remaining power in the internal battery.

CAPACITY

If the down arrow is pressed from the CHARGE position then the display will change to CAPACITY. Pressing the right arrow from this point will indicate the capacity of the battery installed (4.5 Ah). If a different capacity battery is being installed in the machine then the capacity can be selected by pressing the down arrow until the correct capacity is displayed and the EXE key is hit. The possible settings are 1.0 Ah, 4.5Ah, 5.0Ah, 5.5Ah or 6.0 Ah. If the capacity rating is changed for the internal battery then the machine will assume that a new fully charged battery has been installed and will therefore automatically set the % to 100%.

The 1 Ah setting is especially for those who wish to use the machine with external batteries, portable, and to keep the overall weight of the machine to a minimum. When the internal battery display reaches 20% and the internal battery is not being charged from an external source then the BATT led will flash on for 1 second periods every 5 seconds to indicate that the battery is getting flat. When the internal battery falls below 10.8V then it is considered flat, and the display is set to 0% even if it previously read higher.

INPUTS SELECTION

This position in the menus allows the operator to select the status of the audio inputs of the machine. As the NAGRA-D has both analog and digital inputs, then the required ones need to be selected. Muting and copying possibilities are also possible. This setting can be stored in a template if desired.

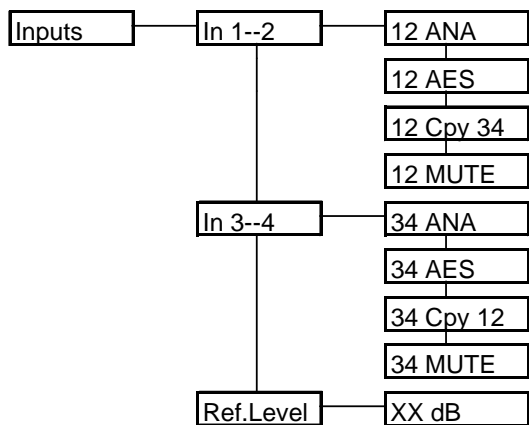

IN 1--2 If the right arrow is pressed with INPUTS on the display it will change to IN 1--2 indicating the setting for channels 1 and 2 is being looked at, and when pressed again will indicate ANALOG, AES, COPY 3--4 or MUTE. If execute is pressed then the inputs 1 and 2 are set according to the current display. Pressing the down arrow will scroll through the other choices. The AES position is the position to be used if the digital inputs of the machine are to be used. Copy 3--4 means that the inputs 1 and 2 are set to copy the information that is being sent to channels 3 and 4. This is done digitally within the machine and the copy will be made whether the analog or digital inputs 3 and 4 are being used or not.

IN 3--4 Once a selection for inputs 1 and 2 has been made, the display will automatically move to the position IN 3--4 and by pressing the right arrow (and then the down arrow) the same possible selections can be made for the other two inputs.

REF LEVEL If the down arrow is pressed again after IN 3--4 then the display will change to REF LEVEL which is the internal reference oscillator. Pressing the right arrow will change the display to XX dB. Pressing the down arrow allows the level to be changed. The level of the reference can be set at any value from 0 dB to -20 dB in 2 dB steps. When the EXE key is pressed then the generator is activated, and will remain so until the display is changed to another indication. If the machine is now put into RECORD mode the internal generator will be recorded onto the tape (assuming the audio channel selectors are in the READY position).

NOTE: The overload leds will always be alight when the reference oscillator is activated irrespective of the level selected. This is because the reference level is always generated and recorded at 0 dB and the chosen output level is created during playback according to the commands recorded on the tape.

SAMPLING FREQUENCY SELECTION

The sampling frequency selection is used to select the sampling frequency of the internal A/D converters, and to select the necessary internal clock frequencies. The NAGRA-Ds internal converters can sample at 32, 44.1 and 48 kHz only. However the machine is also capable of recording 96, 88.2 and 64 kHz providing the signal is an AES signal coming in from an external A/D converter. If one of these higher frequencies is selected then the machine will automatically switch to the DIGITAL IN mode and it will be in 2 channel mode where AES 1+2 is for the left channel and AES 3+4 is for the right channel. In this mode of operation the modulometers 1 and 3 are used to display the left and right channels respectively and the faders 1 and 3 only are operational. Monitoring on the headphones is also switched accordingly.

The NAGRA-D is capable of playing back tapes recorded at one sampling frequency at a different sampling frequency. For example a tape recorded at 48kHz can be played back at 44.1 kHz. The only difference will be that the sound will be "slower". It is quite easy to make this mistake. Naturally when the tape is played at a sampling frequency other than that at which it was recorded then the whole transport will change speed. The scanner will also change speed. This will cause problems with synchronization as the time code will also change speed. The actual sampling frequency recorded on the tape can only be visualized on the screen of the PC in the NADCOM software. This setting can be stored in a template if desired.

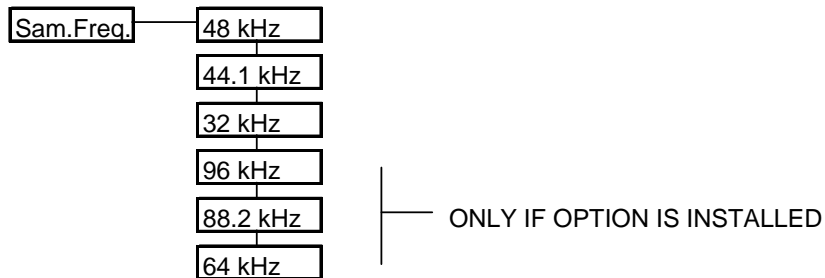

SAMP FREQ This is the indication if the down arrow is pressed from the INPUTS position. If the Right arrow is pressed then the display will indicate the presently selected sampling frequency (i.e. 48 kHz) the down arrow will then move through the other options which are 44.1 (kHz) and 32 (kHz). If execute is pressed while one of these is on the display then that value will be selected as the digital sampling frequency for the incoming analogue audio signals.

NOTE: If a tape is played back and its sampling frequency does not correspond to the sampling frequency presently selected in the machine then the FLAG 1 indication on the display will be lit. This is only operational when using 32, 44.1 and 48 kHz (This feature will not work if the machine is in the EE position).

REFERENCE FREQUENCY SELECTION

This is the reference frequency selection that tells the machine to which signal the clocks of the machine are to be synchronized. Generally the machine will be synchronized to its internal crystals (in the MASTER position), which will guarantee the correct sampling frequency and the full dynamic range. It is however possible to select another external reference, by moving through the possible choices using the arrow keys. If an external reference is being used then this signal must be stable. Pressing EXE on any of these positions will select the displayed choice as reference, and a single beep will be heard. These selections can be stored in a template if desired.

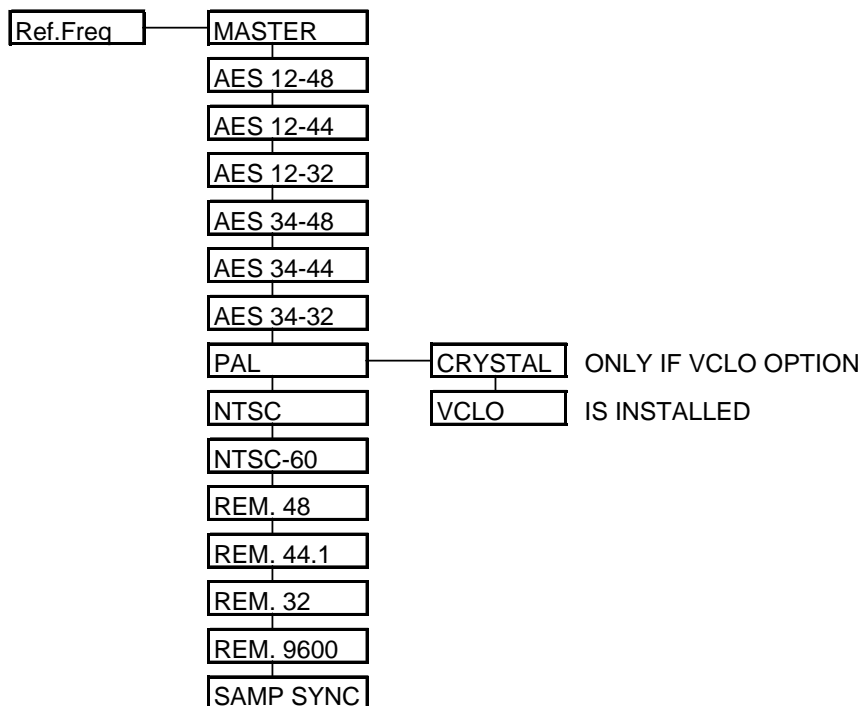

MASTER	Machine is set to be the master, and all internal clocks are synchronized using the internal crystals.
AES 12-48	External ref to be used is arriving on the digital inputs 1 - 2 at 48 kHz
AES 12-44	External ref to be used is arriving on the digital inputs 1 - 2 at 44.1 kHz
AES 12-32	External ref to be used is arriving on the digital inputs 1 - 2 at 32 kHz
AES 34-48	External ref to be used is arriving on the digital inputs 3 - 4 at 48 kHz
AES 34-44	External ref to be used is arriving on the digital inputs 3 - 4 at 44.1 kHz
AES 34-32	External ref to be used is arriving on the digital inputs 3 - 4 at 32 kHz
PAL	External reference is on the BNC connector in PAL 25 fps
NTSC	External reference is on the BNC connector in NTSC 29.97 fps
NTSC 60	External reference is on the BNC connector in NTSC 30 fps
REM 48	External reference is on the 15 pole "D" type at 48 kHz
REM 44	External reference is on the 15 pole "D" type at 44.1 kHz
REM 32	External reference is on the 15 pole "D" type at 32 kHz
REM 9600	External reference is on the 15 pole "D" type at 9600 Hz
SAMP SYNC	Reference signal out on the 15 pole "D" type for sample sync record and playback.

NOTE: If an external selection is made, yet no signal is present the ALARM led will flash.

Machines fitted with the VCLO 14 MHz. input reference possibility.

In normal operation the NAGRA-D's external reference must be very stable and close to the tolerances of the internal crystals (100ppm) otherwise the alarm led will flash to indicate loss of synchronization of the internal clocks of the NAGRA-D. The alarm led indicates that digital IN or OUT is impossible.

If the NAGRA-D is fitted with the VCLO option, the machine can use an external clock reference that is not exactly at the correct frequency. An example of such an application would be to feed the video reference of NTSC (59.94) to the external video reference connector and to set the REF FREQ. selection in the MENU mode to NTSC 60. the internal clock reference of the machine will then slow down by 0.1%, the AES outputs will still be usable and the output sampling frequency will be 44.056 kHz (if the original was 44.1 kHz) or 47.995 (if the original was at 48 kHz).

This VCLO function is on the inputs of the external clock reference and has nothing to do with the VAR CLK position for the time code reference and should not be confused.

The VCLO option can be selected in the menu mode by going to the REF FREQ position and moving to the desired reference (i.e. NTSC) and then pressing the right arrow key and the display will then indicate CRYSTAL (indicating VCXO operation) if the down arrow is then pressed then the display will show VCLO. This selection is possible for all the reference positions, with the exception of the MASTER position where the machine will always use its internal crystals (VCXO).

NOTE: The installation of this option can be made on machines with serial number 1000600 or higher and this requires the installation of the software version V1.03 for the CPU or higher.

TAPE SPEED SELECTION

This selection allows the operator to select either the standard tape speed (99.2 mm/s) for four track operation, or the two track position (49.6 mm/s). In the two track position only channels 1 and 2 are operational. In the two track mode of operation, the machine will give 2 hrs of stereo operation using a single 5" reel of tape. During operation at the slow speed, the ECC display will indicate FA permanently for the right two digits as there are no tracks 3 + 4 on the tape. The default mode of the machine is the four track position. Pressing EXE when the desired speed is on the display will select it. This setting is stored in memory and need not be set each time the machine is powered up. This selection can be stored in a template if desired. All counter / remaining tape indications depend on the selected mode.

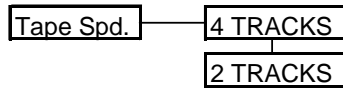

NOTE: If the DIRECTORY mode of the machine is ON then it is forbidden to change from 4 track to 2 track operation (or vice versa) during a tape.

DIRECTORIES

This position in the menu tree allows the operator to have access to the tape directory function. Moving to the right from this position will display MODE and moving again to the right will give the choices ENABLE or DISABLE to either turn ON or OFF the directory mode. The operation of the directories can be stored in a template if desired. A more detailed explanation of the contents and the operation of the NAGRA-D's tape directories can be found later on in Chapter 3 of this manual.

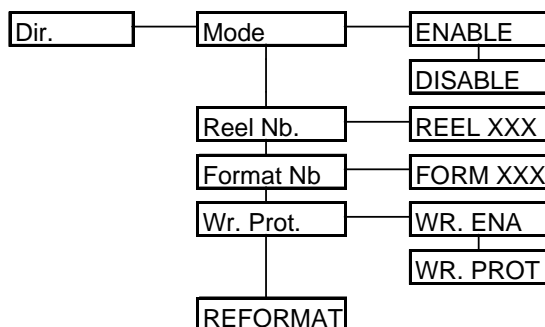

Reel Nb Pressing the down arrow from the MODE position will display Reel N°. Moving to the right from this position allows the operator to enter the reel number (from 0 to 999) using the down arrow key to change the value of the flashing digit and the right arrow to select the next digit. Pressing EXE will then store this reel number.

Format Nb Pressing the down arrow from the REEL Nb. position will display FORM Nb. Which is the number to be placed on the next tape that is to be formatted. This allows the operator to select the number of a tape before it is formatted. Moving to the right from this position allows the operator to enter the reel number (from 0 to 999) using the down arrow key to change the value of the flashing digit and the right arrow to select the next digit. Pressing EXE will then store this reel number ready for the next formatting. If this number is not changed by the user then it is automatically incremented each time a new tape is formatted. If "Mem Lost" occurs then the number will be reset to zero.

Wr. Prot This selection allows the user to WRITE PROTECT tapes. This is done by storing the command in the tape directory and protects the tape against accidental recording. If a recording is attempted once the write protect has been enabled then the display will indicate WR.PROT. This protection will even prevent a directory from being modified. Move to the right and press the EXE key when WR. PROT. Is displayed to protect a tape and WR. ENA. To allow a tape to be written again. The default mode of the machine is the ENABLE position.

REFORMAT Pressing the down arrow from the FORM Nb. position will move to the REFORMAT display. This function is used to erase the directory from the beginning of the tape **AND WILL ERASE THE FIRST PART OF THE RECORDED TAPE** while this is happening, the display will indicate "Erasing". If the REFORMAT command is executed the display will first indicate "SURE ?" which will require EXE to go ahead or ESC to abort. This is simply a protection to avoid accidental reformatting and consequent loss of information. However if the tape is WRITE PROTECT then the EXE command will not be executed. The write protect must be removed first.

NOTE: The REFORMAT command will not work if the tape has been "WRITE PROTECTED"

The operation and contents of the directories is covered in more detail at the end of this chapter under TAPE DIRECTORIES.

OTHER SETTINGS

This option allows access to various features of the machine that are not normally looked at on a regular basis, and do not fall under any other category. Among other things, it allows the operator to either enable or disable the beep option, to activate the auto power down option, to look at and set the internal real time clock and also indicates the version of software installed as well as its date of release. In the OTHERSET menu, the scanner ready duration setting can be stored in a template if desired.

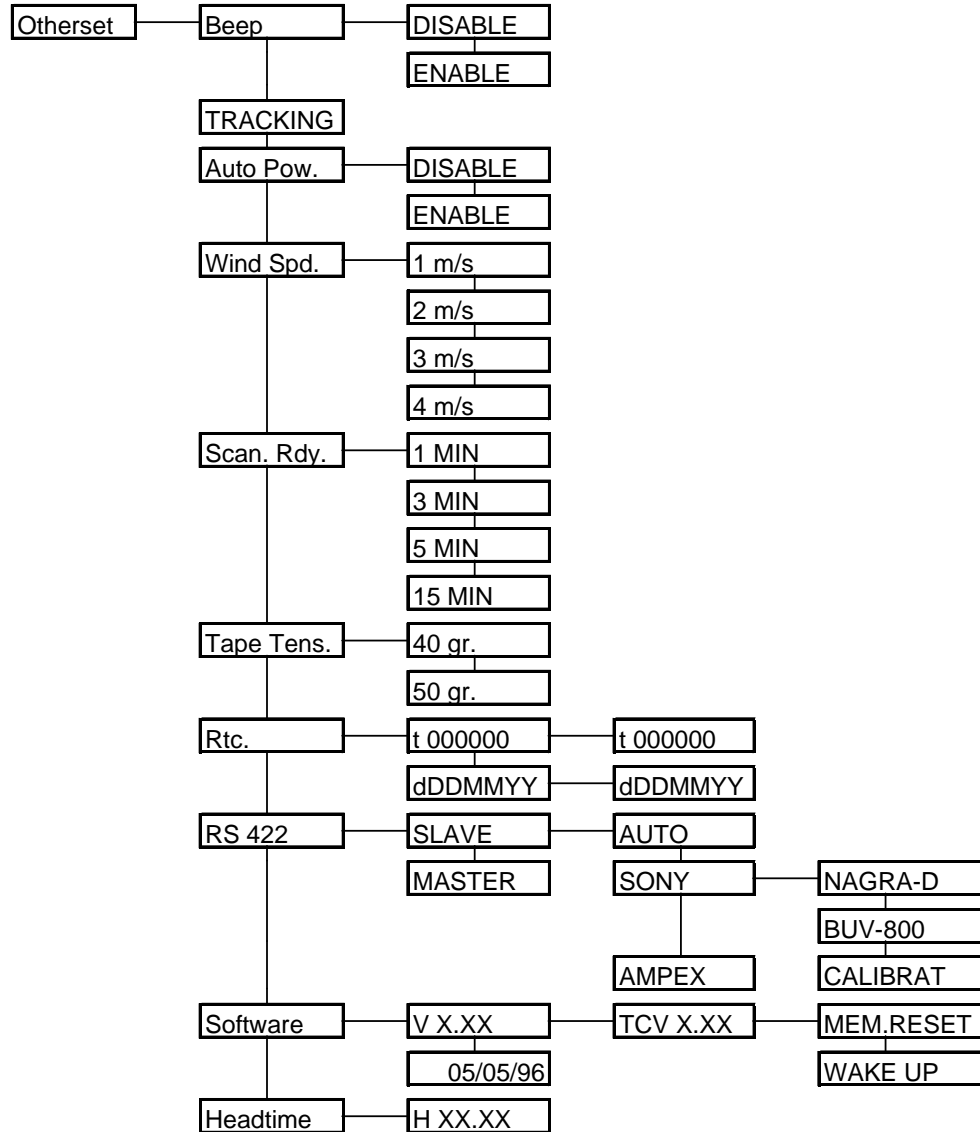

BEEP

The beep function can indicate several different actions within the machine, which are explained below. The options in the menu mode allow the beep signal to be either enabled (meaning that it will be heard on the headphones AND internally via the beeper located within the machine) or it can be disabled in which case it will only be heard on the headphone outputs. As mentioned under battery, a single beep signal will indicate when the machine is about to stop due to insufficient power available from the internal battery. Another operation of the single beep function is when an Assemble is being made.

Two beeps will be heard if a CRASH RECORD on a new tape is made, or alternatively if a feature selected in the menu mode is refused.

If the machine is put into the Record mode and the tape has either a poor or missing control track and the INS / ASS selector is in the INS position, then THREE beeps will be heard and the machine will automatically go into the STOP position. This will also occur if the machine comes across a section of tape that is missing the control track during a recording. If the operator attempts to put the machine into RECORD mode before the tape directory (if the directories mode is on) then 5 beeps will be heard and the machine will refuse to go into record mode. Memory lost on power-up will also emit 5 beeps.

N° of beeps		Description
1	or	Acceptance of an executed command Assemble edit being performed
2	or or or	Crash record on a new tape Refused command Track not located after SKIP or GOTO END. Machine switching OFF in Auto-power mode
3	or	Abort insert edit Missing control track in Record
5	or	Attempted RECORD before the tape directory Memory lost on power up.

TRACKING

If EXE is pressed when "TRACKING" is on the display then the manual tracking adjustment is activated. This will turn the fourth fader pot into a tracking control similar to that on a VHS machine. When this feature is activated, the LCD display will indicate the current tracking value. A Display such as "Tr 119" means Tracking "tr" is currently 119. The RF level is indicated on the fourth modulometer. If problems are encountered reading tapes then adjust the tracking so as to have the highest possible RF level indicated. Monitoring on headphones will clearly indicate the improvement as the RF level gets higher.

AUTO POW

In order to prevent the internal battery going flat when the machine is not in use, the NAGRA-D is fitted with an AUTO POWER DOWN feature which should not be confused with the ND-AP Auto-power option #10230. When the machine is operating on its internal battery, with no external power attached then it will switch off after 15 minutes providing no keys or switches are activated during this period. If the feature is enabled, then this will also be the case even if the machine is connected to the external charger, however it will only come into effect once the internal battery is at 100% so that the machine does not switch itself off during charging. If the feature is disabled, then it will still switch itself off if it is on internal battery operation, as above but it will remain ON permanently as long as there is an external supply providing power. Before the machine actually switches OFF, the BAT led will flash rapidly for 15 seconds to indicate to the operator that the machine is about to turn itself off. Also two beeps will be heard at the moment that the machine goes off.

	EXTERNAL SUPPLY CONNECTED		NO EXTERNAL SUPPLY
AUTO POWER	BATTERY CHARGING BATT < 100%	BATTERY CHARGED BATT = 100%	
ENABLE	No auto power-off	Auto power-off 15mins	Auto power-off 15 mins
DISABLE	No auto power-off	No auto power-off	Auto power-off 15 mins

WINDSPD

The wind speed selection gives the user the possibility to slow down the winding speed of the machine so that the spooling of the reels is even. This feature can be activated in the all modes. The possible speeds that can be selected are in meters per second (4 being full speed). To activate it simply press EXE when the desired speed is on the display.

Winding speed m/s (5" reel)	Time
1	6m 40s
2	3m 20s
3	2m 30s
4	1m 40s

SCAN RDY

The scanner of the NAGRA-D will stay in the ready mode for 1 minute when no key is pressed, before stopping under normal circumstances. This menu allows the operator to select how long it will continue to rotate. The selection can be 1 min, 3 mins, 5 mins or 15 mins. This setting can be stored in a template if desired.

TAPE TENS

The Tape tension selection has been introduced in order to allow the user to select a slightly higher tape tension in PLAY and RECORD modes. If the lower tension is used there may be slight drop in RF signal level at the start of each track with certain tapes. Moving to the right from this display will show the presently selected tape tension (either 40 gr. or 50 gr) and pressing the down arrow will display the other tension. Pressing EXE will select the new value. The setting needs to be selected for 5" or 7" operating positions. The tape tension should be selected for the tape according to the table below:

Low Tension 40 gr.	High Tension 50 gr.
QUANTEGY 467	3M 275 LE
BASF DM 931	
SONY DIGITAL	

RTC

Apart from the time code system, the NAGRA-D is fitted with its own internal real time clock. The time and date of this clock can be accessed through the RTC menu. If the user wishes to set the time and date to a value other than the present one, simply use the right arrow key while looking at the time or date to move to the set mode. In this mode the left most digit of the

display will be flashing and can be altered using the down arrow. Once the desired value is reached then press EXE. All the date modes within the NAGRA-D are in the format DD MM YY. This feature is very important when the DIRECTORIES are being used as it is this information that is used to indicate when (date and time) a certain recording was made. The R.T.C. of the NAGRA-D is year 2000 compatible.

RS 422 This position allows the access to the different RS 422 options. Pressing the right arrow from this indication will display SLAVE or MASTER. The MASTER position is used to send commands to another NAGRA recorder which is connected to the RS 422 port, such as RECORD and STOP commands on the NAGRA protocol via the RS 422 port which will immediately control a second NAGRA-D or a NAGRA ARES-C. In the SLAVE position the machine will wait to receive commands from the external port.

NOTE: The SLAVE position must be chosen in order for the NADCOM software to operate. If the machine is selected to MASTER then the NADCOM cannot communicate with the machine in the normal way.

Machines that have the ND-422S SONY protocol option (#10210) installed will have access to the protocols by pressing the right arrow from the SLAVE position. If the option is not installed then this menu will not appear. The default setting is the AUTO selection which means that the machine will detect which protocol is being used. In some cases it may be necessary to specifically select a protocol, this is done by pressing the EXE key when the desired protocol is displayed. Moving to the right from the SLAVE position gives the possibility for the user to "force" either the SONY or AMPEX protocol. If the Sony protocol is selected to the display, then the user can move to the right and select the type of machine to emulate. The possible choices are either NAGRA-D or BVU-800.

CALIBRAT This position only needs to be activated ONCE. If the SONY protocol is being used to control the NAGRA-D then the machine needs to do an automatic calibration to correctly interpret the speed commands. To perform the calibration, place any piece of tape on the machine and press "EXE" when Calibrate is on the display. It will take about 10 seconds and the results will be stored in the E²PROM and will be remembered even when the machine is powered down. The PLAY led will blink and the display will indicate "Wait..." during the calibration process and then "done" when the calibration is complete.

SOFTWARE This is to display the version of the CPU software installed in the machine. If the right arrow is pressed when this is on the display then the actual number will appear. It will indicate V X.XX which corresponds to the version number of the software for the main micro-processor. If the right arrow is pressed then the display will show the version of the software installed on the time code circuit. If the down arrow is pressed while the machine version number is being shown, then the display will indicate the date of the software release.

MEM RESET If the right arrow is pressed when the time code version of the software is on the display then the display will move to the MEM RESET position. This feature will reset all the default settings of the menu tree, and will erase any directories etc. that may be in memory. To activate it, press EXE and the display will ask SURE ? and EXE a second time will confirm the request.

WAKE UP This position allows the user to store personalized "default settings" of the machine that will automatically be restored when the memory of the machine is lost. Set all the menu options of the machine to the desired positions and press EXE when WAKE UP is on the display. The message SURE ? will then be displayed. Pressing EXE again will then confirm the selection.

BEWARE - AFTER THIS OPERATION THE DEFAULT SETTINGS OF THE MACHINE WILL BE PERMANENTLY CHANGED.

HEADTIME When the right arrow is pressed from this position, then the display will move to the headtime display. This is the indication of the number of hours that the pinchwheel carriage of the machine has been in its forward position (tape in contact with the scanner in Record or Play modes). It indicates the time in hours and tenths of hours. This indicator is for those who wish to charge for the machine based on the amount of use that it has. It is very difficult to use this indication as an accurate timer for head life as the actual life of heads can vary greatly

depending on different factors such as operating environment, tape type etc.
This counter CANNOT BE RESET.

NOTE: The actual lifetime of a set of heads is difficult to estimate but generally about 1'000 hours is quite normal.

FADER POT SELECTIONS

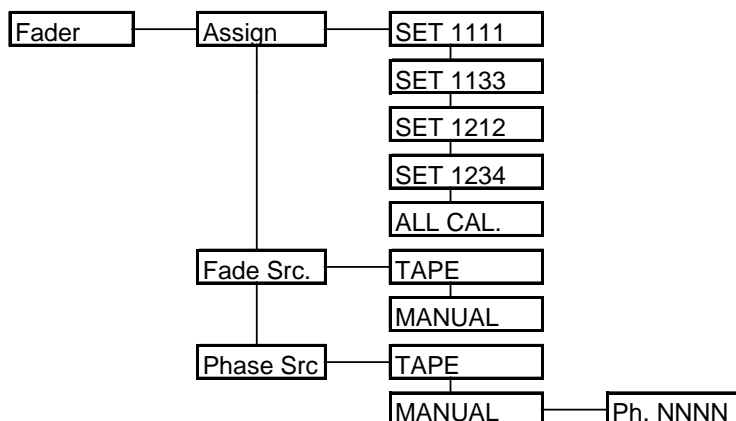

FADER This position in the menu allows access to some of the possible features of the fader potentiometers. The FADER pots in the machine allow several other features other than simply the FADE command. These include, FADE OVERRIDE and PHASE OVERRIDE.

ASSIGN The ASSIGN position allows the operator to assign the configuration of the fader potentiometers in their normal mode of operation. Moving to the right from here will indicate the present configuration. The default setting is 1,2,3,4 which means that fader pot # 1 acts only on channel 1, fader pot # 2 acts only on channel 2 etc. There are other possibilities that can be chosen, to allow multiple channels to be controlled from different pots when making fades. The choice is selected by pressing EXE when the desired selection is displayed. This is not remembered when the machine is switched off. If 1,1,1,1 is selected then all four channels will react to the position of the fader pot # 1. If 1,2,1,2 is selected then channels 1 and 3 will be controlled by the fader pot # 1 and the channels 2 and 4 will be controlled by the fader pot # 2. If 1,1,3,3 is chosen then the channels 1 and 2 will be controlled by the fader pot # 1 and the channels 3 and 4 will be controlled by the fader pot # 3. This setting can be stored in a template if desired.

ALL CAL. If EXE is pressed when in the ALL CALIBRATE position, then the machine will ignore the current positions of the fader pots and will set each one to the calibrated position and the green leds will all light. Even if the pots are now moved the faders will remain in the ALL CAL. position.

FADE SRC This selection allows the operator to decide from where the fade commands are to be taken during playback. Either those initially recorded onto the tape or new ones made from the keyboard manually. This setting can be stored in a template if desired. This can be used to re-make fades after the event.

PHASE SRC In the PHASE SRC position, the position of the PHASE switches (also recorded) can be selected to use either those recorded or those presently selected on the front panel (if MANUAL is selected). If the right arrow is pressed when in the TAPE position the display will show four digits separated by comma's corresponding to the recorded PHASE position of channels 1,2,3 and 4 respectively. This setting can be stored in a template if desired.

"N" represents NORMAL
 "I" represents INVERTED

TEMPLATE

The template settings position gives the user the possibility to store in the EEPROM a personalized settings for the menus of the machine. All the required settings should be set for the particular application and then the number of the template to be used by pressing STORE 1, 2, 3 or 4. From then on each time the RECALL 1, 2, 3 or 4 is pressed then their respective settings will be restored.

As this information is stored in the EEPROM of the machine the settings will not be lost if the internal battery of the machine is removed.

All the possible settings that can be stored in a template are indicated on the main menu drawing at the beginning of this section by a grey shading on the main menu tree.

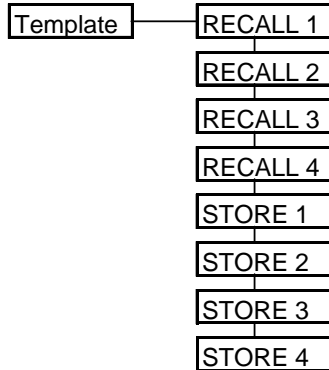

COPY

The copy menu will allow a MIRROR COPY of a NAGRA-D tape onto another NAGRA-D. In order for this feature to operate, a special RS 422 (ND-RSC # 10905) cable needs to be installed between the two machines. (See Mirror Copy later in chapter 3 of this manual for more details).

Move to the right using the arrow key and press EXE to start the copy function.

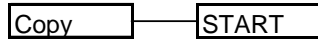

NOTE: If the second machine is not connected or has software prior to version 2.00 the master machine will display NO RS 422.

ALPHA-NUMERIC LISTING OF MENU DISPLAYS

DISPLAY	Description
+000000	Time code offset value during MODIFY
+H00 M00	Hours + Minutes of time code offset
+S00 F00.00	Seconds + Frames of time code offset
0.15 FRAM	Synchronizer reaction time in frames
1 m/s	Winding speed 1 m/second
1 MIN	Scanner ready duration
1.0 Ah	Battery Capacity
12 AES	Audio Inputs 1 + 2 set to Digital
12 ANA	Audio Inputs 1 + 2 set to Analogue
12 Cpy 34	Audio Inputs 1+2 set to copy Information from Inputs 3 + 4
12 MUTE	Audio Inputs 1 + 2 Muted
15 MIN	Scanner ready duration
2 m/s	winding speed 2 m/second
2 TRACKS	Half speed two track operation
24 FPS	Time code frame rate
25 FPS	Time code frame rate
29.97 DF	Time code frame rate
29.97 FF	Time code frame rate
3 m/s	Winding speed 3 m/second
3 MIN	Scanner ready duration
30 DF	Time code frame rate
30 FF	Time code frame rate
32 kHz	Sampling frequency
34 AES	Audio Inputs 3 + 4 set to Digital
34 ANA	Audio Inputs 3 + 4 set to Analogue
34 Cpy 12	Audio Inputs 3+4 set to copy Information from Inputs 1+2
34 MUTE	Audio Inputs 3 + 4 Muted
4 m/s	Winding speed 4 m/second
4 TRACKS	Full speed 4 track operation
4.5 Ah	Battery Capacity
40 gr.	tape tension
44.1 kHz	Sampling frequency
48 kHz	Sampling frequency
5 MIN	Scanner ready duration
5.0 Ah	Battery Capacity
5.5 Ah	Battery Capacity
50 gr.	tape tension
6.0 Ah	Battery Capacity
64 kHz	Sampling frequency
88.2 kHz	Sampling frequency
96 kHz	Sampling frequency
ABS.TIME	Absolute tape time from beginning
AES	Time code Input / Output Delay set to digital
AES 12-32	Clock reference set to AES input 1+2 at 32 kHz sampling
AES 12-44	Clock reference set to AES input 1+2 at 44.1 kHz sampling
AES 12-48	Clock reference set to AES input 1+2 at 48 kHz sampling
AES 34-32	Clock reference set to AES input 3+4 at 32 kHz sampling
AES 34-44	Clock reference set to AES input 3+4 at 44.1 kHz sampling
AES 34-48	Clock reference set to AES input 3+4 at 48 kHz sampling

ALL CAL.	All fader potentiometers set to the CAL position
ANALOG	Time code Input / Output Delay set to analogue
ASSEMBLE	Time code assemble recording
Assign	Fader Potentiometer assign mode
Auto Pow.	Automatic power-off feature
Bat XX %	Battery reserve indication
Beep	beep feature
BUV-800	Emulation of a SONY BVU 800 under RS 422 control
CALIBRAT	Calibration of tape speeds under Sony RS 422 control
Capacity	Battery Capacity
Charge	Battery reserve selection
Chase	Chase Synchroniser mode
Copy	Tape copy feature
CRYSTAL	Reference for machines fitted with VCLO
DATE	Time code / Real time clock date
DATE INC.	Automatic incrementation of time code date
dDDMMYY	Date setting mode
DelaY	time code Input / Output delay
Dir.	Directory menu
DISABLE	Disable a feature
Discont.	Discontinuity handling feature of the time code system
DISPLAY	Principle display
DISPLAY 2	Secondary display
ECC	Error Correction Code indication
ENABLE	Enable a feature
EXT.	Time code recording source
Fade Src.	Fader potentiometer Source
Fader	Fader potentiometer menu
FIX CLK.	Fixed Clock time code reference
FORM XXX	Format number of tape currently on the machine
FORM. Nb	Format number of next tape to be formatted
Format	Format of the internal time code generator
FREE	Free user bits mode
FREE INC.	Free user bits mode with automatic incrementation
FREE RUN	Free running mode of the time code generator
FROM EXT	Setting internal time code from an external source
Gen	Access to the internal time code generator
Gen Mode	Operating mode of the internal time code generator
GEN.OUT	Send Generator to the time code output
H XX.XX	Head useage in hours
Headtime	Head useage menu
In 1--2	Audio inputs 1 + 2
In 3--4	Audio inputs 3 + 4
Input	Time code delay reference
Inputs	Access to audio inputs menu
INT. GEN	Internal time code generator to be recorded
MANUAL	User control of Faders and Phase controls
MASTER	Main reference for clocks / machine not SLAVE
MEM.RESET	Reset the C.P.U.
Mode	Directory mode
Modify	Offset modification using fader pot. 4
NAGRA-D	Machine identification in Sony RS 422 control

NTSC	Video reference Colour
NTSC-60	Black and white video reference
Offset	Time code offset
Otherset	Additional settings of the machine
Output	Time code delay setting
PAL	Video reference Colour
Phase Src	Phase switch source
Reac.time	Time code synchronizer reaction time
REC. RUN	Record run only of the internal time code generator
Rec.Src.	Time code recording source
RECALL 1	recall template 1
RECALL 2	recall template 2
RECALL 3	recall template 3
RECALL 4	recall template 4
Reel Nb.	Current reel number
REEL XXX	Setting of reel number
REF. TC	Time code reference for the synchronizer
REF.FR.P.	Video frame pulse reference for the synchronizer
Ref.Freq	reference frequency for the main clocks of the machine
Ref.Level	Reference generator level
REFORMAT	Reformat of the header of a tape in Directory mode
REM. 32	Remote reference on Extension connector at 32 kHz
REM. 44.1	Remote reference on Extension connector at 44.1 kHz
REM. 48	Remote reference on Extension connector at 48 kHz
REM. 9600	Remote reference on Extension connector at 9600 Hz
REMAIN	Remaining tape time
RESET	Reset the internal time code generator
ROLLER	Cdisplay the tape counter roller
RS 422	Remote control by 9-pin RS 422 SONY protocol
Rtc.	Real Time Clock
SampSYNC	Sample sync selection
Sam.Freq.	Sampling frequency of the internal A/D converters
Scan. Rdy.	Scanner ready menu
Set	Set the offset for the internal time code synchronizer
SET 0%	Selection of battery charge
SET 100%	Selection of battery charge
SET 1111	Selection of fader control to pot #1
SET 1133	Selection of fader control to pot #1 and #3
SET 1212	Selection of fader control to pot #1 and #2
SET 1234	Selection of fader control to pot #1 #2 #3 and #4
SET 25%	Selection of battery charge
SET 50%	Selection of battery charge
SET 75%	Selection of battery charge
Set Gen	Setting of internal time code generator
Set Time	Setting of time portion of internal time code generator
Set User	Setting of User portion of internal time code generator
SLAVE	Selecting machine as a SLAVE rather than MASTER
Software	Software menu
START	Activate the mirror copy function
STORE 1	Store menu settings in memory 1
STORE 2	Store menu settings in memory 2
STORE 3	Store menu settings in memory 3

STORE 4	Store menu settings in memory 4
Sync	Access to Synchronizer manu
Sync Mode	Access to clock mode of synchronizer
SYNC.	Activate the chase synchronizer
Sync. Inc.	Activate the chase synchronizer in incremental mode
t 000000	Setting of the time for the Real time clock
TAKE	Take number display
TAPE	Reference for the Fader and Phase commands
Tape Spd.	Selection of the tape speed of the machine
Tape Tens.	Tape tension selection menu
Tapeform	Time code format of the tape on the machine
tc	Time code display selection
TC DELTA	Display of time code delta
TC OUT	Display of offtape time code
TC REC	Display of time code to be recorded
Template	Menu storage template menu
TIME	Time portion of time code display
TimeMode	Time mode operation of the internal time code generator
TRACKING	Longitudinal tracking control
USER	User portion of time code display
User Mode	Operational mode of the user bits of the time code
V X.XX	Software version for the CPU
VAR.CLK.	Variable clock reference for the time code synchronizer
VCLO	Voltage controlled local oscillator for clock references
WAKE UP	User selectable default modes
Wind Spd.	Longitudinal winding speed
WR. ENA	Write enable of a tape
WR. PROT.	Write protect of a tape
XX dB	Audio reference generator level

CUE TRACK

As mentioned in chapter 1 of this manual, the NAGRA-D has a longitudinal CUE track located along the upper edge of the tape which has two main functions. Either the recording of an external cue microphone for commentary purposes, or a recording an analog mix of the 4 digital channels will be placed on the CUE track.

NOTE: Recording of the Cue channel after the original recording has been made will result in future playback problems, as this type of recording will corrupt the control track already recorded on the tape.

USING THE CUE TRACK

Check that the CUE channel lock-out switch is set to the READY position. When the machine is put into record mode the cue track will automatically record a mixture of the four audio channels, either from the digital or analog inputs depending on the input selections made. The information for the cue track is recorded on a longitudinal track at the top of the tape (see "footprint") and is recorded in analog by the longitudinal head that is also used to record time code and the control track. The signals are taken after the D/A converters, which means that even if the input signal to the standard audio channels is being supplied in the AES format to the two digital inputs, an analog signal is still recorded on the cue track. The advantage of this mode is that in EDIT mode (EXE + PLAY) the cue track can be read and fed to the headphone outputs allowing location of a particular section of the tape audibly at speeds other than nominal. The direction of the tape and its speed is controlled by the fader pot # 4 during this mode.

In order to listen to the cue track during normal playback, the headphone mode selector can be put in the CUE position, and then the monitoring is only made on the cue track. (If the headphone outputs are selected to monitor the normal helical tracks then the monitoring will automatically switch to the cue track when the tape is not at nominal speed.) When the machine is put in playback mode the cue track is now fed to the headphone outputs. If the fast forward or fast rewind keys are pressed while in the playback mode then the tape will move at 4 times nominal speed (or 8 X if pressed twice) in the corresponding direction, thus allowing audible searching off tape by monitoring the longitudinal cue track.

USING THE ND-CM CUE MICROPHONE

The ND-CM is the cue microphone adapted for use with the NAGRA-D. When connected to the 15 pin EXTENSION connector on the left-hand side of the machine, the cue track can be used to record commentary upon pressing the small black button on the cue mic. (Assuming that the cue track lock-out selector is in the READY position). It should be noted that the CUE track will also record the mixture of the four digital channels and any commentary made will be recorded in addition to this. The ND-CM cue microphone can only be used during the initial recording (unlike on the NAGRA IV-S where it can also be used during playback), as a signal recorded on the cue track during playback will interfere with the control track already recorded on the tape.

MONITORING ON HEADPHONES

The NAGRA-D is fitted with two ¼" Jack headphone outputs located on the right-hand side of the machine. This has been done to prevent the operator removing his headphones in order to allow a third party to monitor the recording. The headphone outputs are taken after the D/A converters, so that even when working in the digital domain the signals can still be monitored. On earlier versions of the NAGRA-D, the output level of these headphone outputs is controlled via a 5 position switch located directly above them. On newer machines this has been replaced by a potentiometer. This volume control acts for both outputs together. The selection of the signals fed to the headphone output connectors is governed by the monitoring selectors on the main control panel.

The four headphone selection switches function in conjunction with the mode selector switch 2 and the direct switch 3 (see chapter 2 for these references). There are four switches (each corresponding to one channel) each having three positions. These positions are SOLO / ON / OFF. The SOLO position is a snap switch and must be held in the SOLO position. When in the SOLO position, the signal from the selected channel is centered on the headphone outputs, and the other channels are inhibited. The four (1, 2, 3, 4) headphone switches are also labeled L, R, L, R respectively. This means that if selector 1 is ON then the signal will be fed to the left channel of each of the headphone outputs. If selector 2 is ON then it will be fed to the right channel and so on. Thus stereo monitoring between two channels is possible between the following combinations: 1+2, 1+4, and 2+3. The combination of 1+3 is not possible as they would both be on the same channel superimposed.

The headphone mode selector is a three position switch which selects the mode of the headphone outputs. The three positions correspond to MONO / STEREO / CUE. In the cue position the headphone outputs monitor the longitudinal CUE track. The STEREO position is the normal operating position and in the MONO position all 4 channels will be in MONO.

Under normal operation, the headphone outputs are automatically switched to the CUE track as soon as the machine is not at nominal speed, allowing rapid audio location of portions of the recording.

If the ND-HSF High Sampling Frequency option is installed in the machine and external converters are being used then the monitoring will only be on channels 1 and 3 and will also be at 48 kHz due to the internal D/A converters.

NOTE: Monitoring on the NAGRA-D is made using the internal D/A converters and therefore the resolution is limited to 18 bits and 48 kHz sampling frequency.

EDIT MODE (SEARCH)

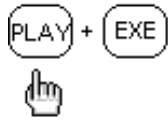

This mode is selected by pressing EXE and PLAY which is marked EDIT above the playback key. Once it has been switched ON then the speed and the direction of the tape can be controlled using the fader potentiometer corresponding to channel 4. When this mode is selected the monitoring is made on the longitudinal CUE track (which either has a mix of the 4 digital channels and/or commentary recorded on it). Using this mode, the operator can rapidly locate specific sections of the recording audibly. To stop the search / shuttle mode, simply press the STOP key on the main control panel. The search mode will allow the machine to move from -1 to +1 times nominal speed. During the search mode both of the leds REW and FF will be alight. If the fader pot is put into its central position, the tape will stop moving and, after 3 seconds, the tape guide carriage will move back, taking the tape away from the drum and the PLAY led will start to flash. This is done to prevent unnecessary tape and head wear, caused by the scanner turning against the same point on the tape. The play led will flash until the fader pot is moved again, which will immediately revert to the edit mode.

MICROPHONE INPUTS

Audio sound recordists are used to working with mixing consoles equipped with a sliding "fader" potentiometer and a "pad" to obtain the operating level / input sensitivity, for each microphone input. Initially, the pad position is set to give approximately zero dB and is then left in the same position for the entire recording. Any fine adjustments, made during the recording, are done using only the fader. If this method is used for a recording that begins at a signal level of -40dB, then as the level increases during the recording, the slider is slowly lowered to compensate, and there becomes a point where the inputs are saturated.

If the reverse occurs, that is to say a normal recording is being made, and the level slowly falls off in a quiet portion to -40 or -50 dB then the inherent noise of the source (microphone for example) becomes too great.

The user may take the precaution of keeping a suitable reserve by means of the input sensitivity attenuator (pad). However, in this case, it is the noise that limits the performance of the input amplification chain. Calculation shows that, in order to guarantee a dynamic range of 108 dB necessary to make a recording with 18 bits, guarding a reserve of 20 dB is only possible at the cost of heavy power consumption, as the reserve is lost across the potentiometer, which is not practical in a self-contained recorder.

To work using a system based on 18 or 20 bit resolution obliges us to use a different philosophy with respect to the input circuitry and also to slightly change the habits of the sound engineers. Many different points came to light while studying the concept of the input circuitry of the NAGRA-D.

- To guarantee a real dynamic range of 108 dB, thanks to the internal levels being very high.
- To clearly indicate to the sound recordist that the positions of the Fade and Level which guarantee an optimal dynamic range are clearly marked.
- To drastically reduce the number of active and passive components in the amplification chain in order to limit distortion and the effects of intermodulation.
- To make the phase errors and group delay negligible by a distribution and a choice of correct RF and anti-aliasing filters.

The sound engineer adjusts the input sensitivity of his microphone and of the approximate recording level by means of the PAD, which is often in the form of a switch. During the recording, he therefore only has access to the fader control in order to refine the recording level, being obliged to accept the inconveniences explained above. In the case of an analog recording or a digital recording limited to 16 bits this problem is minimal. However this is not the case for a recording of 18 or 20 bits.

As the synoptic diagram on the following page shows, the level is adjusted by means of a potentiometer and it is this that will be used during the recording process to insure the correct level at the input of the A/D converter. The range of its adjustment is from +3 dB to -34 dB. That is to say that while operating within these limits the full dynamic range of the A/D converter is guaranteed.

Below -34 dB the thermic noise of the input source (200Ω) on the input, will be greater than the noise of the A/D converter. Above + 3dB, the input stages will be saturated due to the restrictions on the power consumption needed in a self-contained recorder. Having passed through the standard filters (LFA, Speech and Flat) as on other NAGRA portable recorders the signal is then digitized. The next stage of the signal treatment is taken care of by the DSP (or high speed microprocessor whose architecture is destined towards signal processing)

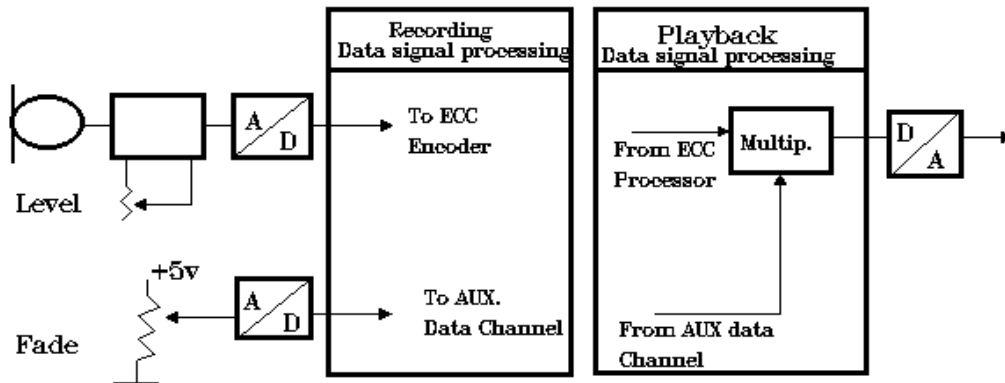

The operation of the Fade is then insured by a software potentiometer. An interesting peculiarity in the NAGRA-D is that the fades are not made on the original recording, but simply the corresponding fader pot position information is recorded as auxiliary data channel and, following these instructions, the fade is then effected during the replay, digitally. The FADER SRC menu can be set to either MANUAL or TAPE. In the manual mode the instructions from the tape are ignored and new fade instructions to the DSP can be generated in realtime during playback. This can be termed "Non destructive fading". The fader pots can also be linked (using the menus) so that two pots can be used to control four channels, or pot # 1 to control all four channels. In the FADER menu it is also possible to select the ALL CAL position where all the faders will be forced to the CAL position despite their current positions.

In passing it should be noted that the audio signals do not pass through the fader potentiometer. The fader simply supplies a continuous flow of instructions, which form multiplication coefficients to the DSP circuits during playback, and these instructions are recorded to the tape. Physically on the NAGRA-D these two controls, Fade and Level, are mounted co-axially.

(Please refer to the photograph of the potentiometers on the following page)

The external ring controls the level and is calibrated from +3 dB to -34 dB, and the center knob controls the fade function. Here another explanation is needed in order to explain the need for two distinctive working areas of the fade control.

The shaded area to the right performs the actual fade function. The area to the left (calibrated 0 to -34 dB) is used to increase the input sensitivity, allowing 0 dB to be indicated on the meter even with a very feeble input signal. However, the noise level will increase equally. For example if the fade control is placed in the -30 dB position, the useable dynamic range will now be $108 - 30 = 78$ dB. As long as the fade potentiometer is in the central position, indicated by the green CAL LED, the user can be sure that throughout the working zone of the level adjustment (external ring), that 18 bits (108 dB) of dynamic range is available providing the peak input level is at or near 0 dB, on the modulometer,

Finally, the sum of the level and fade scales and that of the indication on the modulometer gives the input level in dB/600 Ohms.

Example:	Level	+ 2 dB
	Fade	- 4 dB
	Modulometer	- 4 dB

Input level = $+2 - 4 - 4 = -6$ dB.

In this instance, this indicates an incorrect set up because in the above example the fader is set to -4 and the level allows a further 1 dB (max. +3dB). The fade being at -4 means that we lose 4 dB in signal-to-noise ratio. In this case it would be more advantageous to set the potentiometers as follows:

	Level	+ 3 dB
	Fade	0 dB
	Modulo	- 4 dB

The 108 dB of dynamic range will not be obtained in these examples as the modulometer is indicating -4 dB.

RECORDING

The NAGRA-D can record using ANALOG, DIGITAL and CUE microphone inputs. The selection of ANALOG or DIGITAL inputs is made via the MENU mode under the title INPUT selection. Analog inputs are recorded through the four analog input XLR connectors on the left-hand side of the machine, and the digital inputs through the two AES input XLR connectors. Cue information is a mix of the four audio channels, and if required a CUE signal fed to the EXTENSION connector or from the ND-CM cue microphone. The cue track is fitted with an ALC circuit so all the signals will be recorded at the same level.

It IS POSSIBLE To connect a second machine (either NAGRA-D or ARES-C) to the RS422 port of the master machine to increase the number of channels or make back-up copies. When connected using RS 422 the master machine will send all PLAY, STOP, READY, and REC PREVIOUS commands to the slave machine, which will be controlled remotely by the master machine. The second machine needs to be in the SLAVE position.

RECORDING WITH MICROPHONES

The four XLR inputs on the side of the NAGRA-D are cabled according to the standard XLR pinning. That is to say pin 1 is earth, pin 2 is the signal positive, and pin 3 is the signal return. Unlike the NAGRA 4.2 and IV-S the powering for "T" power microphones is NOT reversed.

Connect the desired microphones to the chosen inputs (remember the stereo pairs are inputs 1 + 2 and 3 + 4). Select the desired type of microphone powering using the rotary selector above each input. Press the POWER ON button. The machine is automatically set to the EE (direct) mode, and the microphone levels for each channel can now be adjusted using the outer ring of the co-axial potentiometers corresponding to each input.

Check that the fader potentiometers are in their CAL position and that the green led above each meter is alight. (these may be turned to increase the input level sensitivity if necessary, if the input level is not great enough). Phase inversion and filters may also be selected using the corresponding switches on the front face of the machine if desired. The direct signal can be monitored on the two headphone outputs.

The default mode of the machine is high speed 4 channel operation.

Set the lock-out selectors to the ready position for the channels to be recorded. Put a new reel of digital tape on the machine and leave the machine to format the directory (if the directory mode is ON) (SEE DIRECTORIES) once this is complete press STOP. Set the INS/ASS switch to the ASS (assemble) position. Set the EE/AUTO/TAPE selector to the AUTO position.

Press the RDY (ready) key and the scanner of the machine will start to rotate, once it is stabilized the yellow led will stop flashing. The machine is now ready to be put into record. Press the REC and PLAY buttons simultaneously, the tape will be laced onto the scanner, and the recording will begin and a beep will be heard in the headphones to indicate that the machine has started recording.

During the recording the input sensitivity may be adjusted if necessary using the input level sensitivity potentiometers and fades may be made with the FADER pots. If the monitoring selector is left in the AUTO position then the monitoring in the headphones is the "off tape" signal. The maximum peak levels obtained during the recording may be seen on the meters by putting the meter switch into the MAX HOLD position, and then reset by pushing the switch to the RESET HOLD position.

It should be noted at this point that if the machine has microphones connected to the analog inputs, and the tape selector switch is in the position AUTO or EE then automatically the inputs are fed to the line outputs while the machine is stationary.

RECORDING A LINE INPUT SIGNAL

The line input connectors are the same connectors as used for the microphone inputs. Connect the line signals to be recorded to the input connectors and set the switches above the connectors to the LINE position. Then proceed in the same manner as explained above for recording with microphones. The maximum input level for the NAGRA-D is +3 dB which is a lot lower than the output of most mixers. The accessory ND-LIA (Line Input Attenuator) should in this case be used for matching. The drawing below shows the respective input levels that can be used with and without the attenuators.

Alternatively, the ND-IL line input option (#10323) can be installed in the machine. It not only allows selection between mic and line inputs but also output levels. With this circuit installed the line input attenuators are no

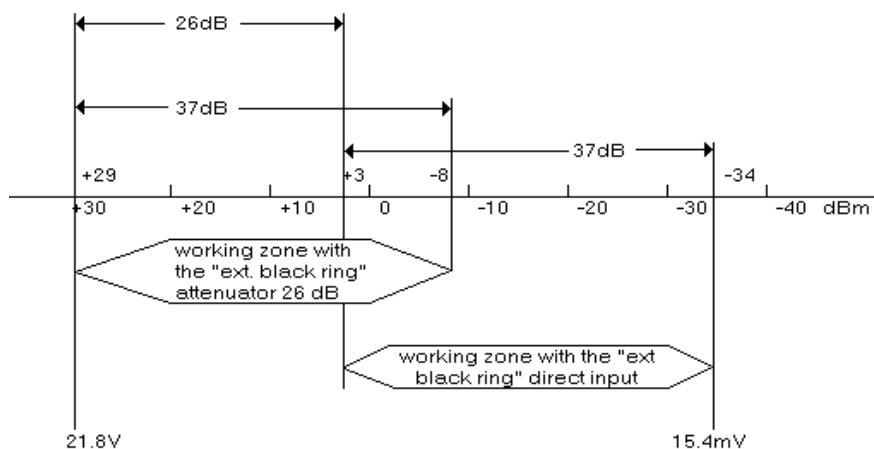

longer necessary.

USING THE ND-IL LINE INPUT CIRCUIT OPTION

The ND-IL is an internal circuit that can be installed inside the NAGRA-D and allows the use of Line input signals without the need for external attenuators. The circuit contains four rotary switches. There is a sticker on the board which indicates the position of the switches. However the two switches on the left side of the circuit S1 and S2 are used to select the line inputs for channels 1 + 2 and 3 + 4 respectively. In the clockwise position the inputs are set to the LINE IN operation. In the counter clockwise position the normal MIC inputs are selected. The other two rotary switches S3 and S4 on the ND-IL circuit, are for the outputs of the circuit, and must also be switched according to whether MIC IN or LINE IN is being used. Again clockwise for Line IN and counter clockwise for MIC in.

RECORDING A DIGITAL SIGNAL.

To record a digital input on the NAGRA-D, firstly ensure that the digital signal being supplied is in the AES format. Put the display of the machine into the MENU mode by pressing the DOWN arrow and INPUTS will be displayed.

Go through the procedure as explained, in detail, under MENUS earlier in this manual, and set the desired pair (or both pairs) of inputs to the AES position. Then proceed to set the reference frequency (it must be set to the same frequency as that of the incoming AES signal, either 32 kHz, 44.1 kHz or 48 kHz) also in the menu mode. The lock-out switches for the channels to be recorded must of course be in the READY position before the machine is put into record. Once this has been done the machine is ready to make the recording. Monitoring is the same as explained above for recording with microphones or line, however, naturally the input level sensitivity potentiometers no longer have any effect on the incoming AES signal. When the digital inputs are being used the overload leds are set to indicate at 0 dB.

PLAYING BACK A RECORDED TAPE

Install the tape to be played back on the machine as explained under "loading a tape". Wait for the machine to take-up the tension and for it to locate the directory (if the directory mode is on) once this is complete then the machine is ready to play back the tape. When ready to play the tape press the PLAY key, the tape will engage and the playback signal will be on the four (or 2) analog outputs as well as the two digital AES outputs. Monitoring of the playback signal on the headphone outputs is of course possible and the selections of the channels must be made with the headphone selection switches. During playback, if either the FF (fast forward) or REW (rewind) keys are pressed then the tape will move in the desired direction at 4 times nominal speed (or 8x nominal speed if pressed twice). The standard outputs will automatically be muted, however monitoring of the longitudinal CUE track is possible on headphones.

If the directory mode is ON then the SKIP features as well as the GOTO END are activated. Pressing EXE + REW will go to the previous take, pressing EXE + FF will go to the start of the next take and EXE + REC will go to the end of the recorded part of the tape. If the directory mode was OFF when the tape was recorded then these features will not operate. Pressing EXE + FF (or REW) successively will skip one "take" upon each pressure. Selection of a particular take to be played back can also be made via the PC using the NADCOM software (see EXTERNAL CONTROL).

MAKING A COPY OF A NAGRA-D TAPE

Copying a NAGRA-D tape is possible in several ways, either digitally onto another NAGRA-D, or digitally onto another recorder having AES bus possibilities, or of course in analog. Making a simple manual copy of a NAGRA-D tape from one machine to another will result in the copy being WITHOUT a directory. (see mirror copy below). Naturally if a tape is copied digitally to another machine (such as an R-DAT) the digital will not be re-dithered. The recorder machine, if it does not have the same quantization (either 18 or 20 bits) then the signal will be truncated.

COPY TO ANOTHER DIGITAL MACHINE

Simply connect the digital outputs of the NAGRA-D to the AES inputs of the other equipment, check that the sampling frequency and reference of the receiving machine are the same as those on the NAGRA-D. Put the recorder machine into record and then press play on the NAGRA-D.

MIRROR COPY OF A NAGRA-D TAPE TO ANOTHER NAGRA-D

The ideal way to copy a NAGRA-D tape is by using the MIRROR COPY function. This feature will allow a tape to be copied to another NAGRA-D as a replica of the original. The copy feature has several other interesting possibilities apart from simply making copies of the originals for back-up purposes.

For example, if a tape has a directory that for some reason can no longer be read due to a drop out, using the mirror copy facility this tape can be copied to another NAGRA-D and the recorder machine will re-create a new directory during the copy process. This new directory will be an exact copy of the original directory.

This feature allows tapes that were originally recorded without a directory to be copied and a directory created at the same time. With the mirror copy function it is possible to copy either a complete tape or simply part of a tape. Making a mirror copy of a NAGRA-D tape has the advantage that all the directory information and auxiliary data will also be copied to the new tape. All the drop out, overload level information will also be copied across. In order to do this, the AES, Time code and a special RS422 cable need to be connected between the machines.

EXPLANATION OF THE PROCEDURE FOR THE COPY FUNCTION

Firstly connect the AES outputs of the master machine to the AES inputs of the destination machine. Naturally if the tape to be copied is a half speed recording then only AES 1+2 need to be connected as there is no audio on channels 3+4. The RS 422 ports need also to be connected together by means of a special adapter/cable which is crossed over (ND-RSC KSA N° 10905). If the machines are time code versions, then the time code connectors also need to be connected with a QCTC LEMO - LEMO cable (#16908).

NOTE: The READY / SAFE switches for channels 1+2 and 3+4 as well as the ASSEMBLE / INSERT switch are manual and must be put into the ready and Assemble positions respectively.

Place the Master tape to be copied onto the master machine, and a formatted tape onto the destination machine. Position the master tape to the point from where it is to be copied. Normally for a complete copy the master tape should be positioned just before take 1. Likewise the destination tape will start to record from wherever it is. Position the two machines as desired preferably by letting the machine auto-position itself after reading the directories, or by using the skip functions so that the correct pre-roll can be positioned.

The actual copy will commence automatically onto the destination machine once the command is sent from the master. This command is sent from the master machine from the COPY menu located in the menu tree after the template menu. Move through the menu tree on the MASTER machine until the copy menu is on the display. Move to the right with the arrow key and START will be displayed. Press EXE on the master machine and the copy will start automatically.

ONLY THE READY / SAFE SWITCHES AND INS / ASS NEED TO BE CHECKED ON THE DESTINATION MACHINE THE REST IS FULLY AUTOMATIC.

As soon as the start command is sent, the master machine will configure all the necessary settings of the slave machine via RS 422. It will automatically set the inputs to AES at the correct sampling frequency, the time code delay settings etc. Both machines will start automatically, the master will be in PLAYBACK and the slave will be in RECORD. If the FADE SOURCE or PHASE SOURCE of the master machine are not set to TAPE (i.e. MANUAL) then the display will indicate "ALT. FADER" to indicate Altered fader positions. Press EXE to confirm that this is the desired mode.

Throughout the copy the slave machine is locked to the master machine. Initially the master will check all the following points before starting the copy:

RS 422 communication check between the two machines. If there is a problem then the message "NO RS 422" will be displayed on the master machine.

Verification that the destination machine is fitted with software version 2.0 or higher. If this is the case then the message "NO RS 422" will also be displayed.

Verification that the destination machine is at the same tape speed as the master (Half speed / Full speed). If this is not the case then the message "Wrong SPD" will be displayed.

The master machine will then put the destination machine at the same sampling frequency.

The master will set the REF FREQ of the destination machine to AES 1+2 at the correct sampling frequency.

The fader pots of the master machine will be forced into the CALIBRATED position.

The FADER SOURCE and PHASE SOURCE of the destination machine are set to RS 422 (rather than TAPE or MANUAL) and during the copy process the RS 422 port will send auxiliary data upon each rotation of the scanner to the slave machine. (Channel source, sampling frequency, overload level, fader positions). The master sends the CAL position and the fader controls (and Phase switches) of the master machine can be used to change levels if desired, however the CAL leds of the destination machine will go OFF if the faders are moved. The master will remain in CAL. Any monitoring of such modifications should be done on the destination machine as the outputs of the MASTER machine will remain in the CAL position.

If the destination machine is equipped with the internal time code option, then the following will also be performed on the destination machine:

- Time code delay to AES INPUTS
- Time code frame rate set to the same as that of the master.
- Time code to be recorded will be set to the EXT TC position

If the time code is not to be copied then the sampling frequency does not need to be kept the same as the original. This means for example that a tape recorded at 32 kHz sampling frequency can be mirror copied at 48 kHz as long as time code is not to be copied, hence the copying time is greatly reduced.

When making a mirror copy 4 principle cases can occur:

1. Both the source machine and the destination machines have a directory on the tape.

If the copy is started at take number 1 then the reel number and title of the tape are also copied to the destination machine. The title of each take, the date and time of the original recording the recording source as well as the sampling frequency are all copied across. All additional information is collected by the destination machine during the copy process.

2. Source tape has a directory, destination machine is without directory

Only the auxiliary data on each track is copied from the master machine to the destination machine.

3. Neither the source machine nor the destination machine have a directory.

Only the auxiliary data on each track is copied from the master machine to the destination machine.

4. Source tape has no directory and the destination machine has (or will have) a directory.

The auxiliary data recorded in each track is used to reconstruct a directory. In other words, the date and time of the recording, the recording source and the sampling frequency are all copied from the master to the destination machine.

NOTE: The date and time which is recorded in the auxiliary data of each track is the actual date and time of the Real Time Clock of the recorder machine and is not copied from the master machine. The date and time that is copied is that which is seen on the Directory management screen of the NADCOM software next to each take number.

The copy can be stopped at any time by pressing STOP on the master machine. It should be noted that the settings that were changed in the destination machine will not be reset to their previous settings after the copy process. If the copy process is interrupted, for example if the RS 422 cable is removed, then "No RS 422" will be displayed and the destination machine will remain in a "bizarre" mode. The destination machine should be turned OFF and then ON again before being used for another operation other than a copy of a tape. Features such as fader source will be left in the RS 422 position for example. If a copy is complete normally then the destination machine will be reset by the master machine.

The copy process will stop automatically after the last recorded track on the master machine providing the master is recorded with a directory, or alternatively if there is a 5 second period without any R.F. signal on the master tape for masters without a directory. This can also be the case if there are more than 99 takes on the tape. Short takes (less than 1 second in length) will be ignored.

COPY CHANNELS 1 + 2 FROM THE NAGRA-D ONTO CHANNELS 3 + 4

This can be done in two ways, either in analog or digital, however generally this will be done in digital. Connect the digital outputs (1 + 2 assuming that the source material is recorded on channels 1 + 2) to the digital inputs 3 + 4. Set the mode selector ASS/INS into the INS (insert) position, make sure that the lock out switch for channels 1 + 2 is in the SAFE position and the lock out switch for channels 3+4 is in the READY position, then put the machine into REC by pressing REC and PLAY together. Channels 1 + 2 will then be copied onto channels 3 + 4. It is also possible to make such a copy during the initial recording process by setting the inputs selection for 3--4 to CPY 1—2 which will make a simultaneous back-up. This can be useful if the levels to be recorded are unknown, the back-up could be made at a different level using the fader pots.

REMOVING THE INTERNAL BATTERY PACK

The internal battery of the NAGRA-D is considered as an integral component of the machine, and it is not something that is supposed to be changed regularly. The use of either the ND-CCC mains charger, or the ND-EPC external DC/DC converter should be used whenever possible. However if it is absolutely necessary to remove the internal battery it may be done by following the instructions below. Switch off the machine by pressing the POWER button, and disconnect any external power supply presently connected to the power socket on the right-hand side of the machine. Loosen the two deck fastening screws on the front of the main control panel. Lift the deck plate of the machine until it is supported by the bracket on the right-hand rear side of the case. Disconnect the battery power cable from the socket. Lift the right-hand side of the metal fastening cover from the battery pack, using a screwdriver, and gently lift it to the left being careful that it does not touch the circuit boards. Carefully remove the battery pack and replace it with a charged one. Reverse the above procedure and then close the machine.

NOTE: If the internal battery is removed from the machine for more than a few minutes then the internal settings of the machine (time code frame rate, sampling frequency presently in use etc.) will be lost and at the next power up, the machine will select the default settings and will display MEM LOST on the display for a couple of seconds and five beeps will be heard to indicate. The battery management system will also assume that the new battery that is installed is fully charged.

TAPE DIRECTORIES

GENERAL

There are two main reasons/functions of the tape directories of the NAGRA-D. Firstly, they serve as a "log book" for each tape/take and secondly they make the machine more ergonomic to use. Of course there are numerous particularities of operation that can have strange effects on the operation of the machine. However simple operation of the machine with the directories, as long as the following "rules" are obeyed, it is relatively simple.

Principle rules:

1. **Always use the same size reels on both of the reel motors (either 5" or 7" never mixed).**
2. **Do not remove the tape in the middle of the reel always wind the tape off.**
3. **Remove the tape by fully REWINDING it whenever possible.**

Exceptions to these rules are possible, however with differing consequences. Reading further in this chapter will give a detailed outline of the operation of the directories, and will explain the possible problems that may occur if these rules are not adhered to. The Directory mode can be switched ON or OFF in the menu mode, and the text below assumes that the directory mode is in operation, if it is OFF the features below will not operate.

WHAT IS A DIRECTORY ?

The directory of the NAGRA-D's tape is a file recorded on the tape which includes a lot of information about the "in/out" points, "takes", "drop-outs" and the "overloads" etc. on the tape. Analysis of the information in the directory can only be accessed fully using a PC equipped with the NADCOM software. On the machine itself, only the take numbers and reel number can be displayed. The major advantage of the directory feature is that the operator can now use the SKIP features (EXE + FF and EXE + REW) as well as the GOTO END feature, in order to locate sections on the tape quickly and easily.

All this means that each and every tape is identified by its directory. The directory also stores a host of additional information such as when the tape was formatted, when the tape was recorded, the input audio channel status during the recording, as well as the sampling frequency used and the position of the fader pots during the recording. The tape directory can also be used to store information such as "write Protect" onto a tape to prevent accidental recording onto the tape. The library of information can be studied in great detail using the NADCOM which is explained in detail in Chapter 5 of this manual.

WHERE IS A DIRECTORY RECORDED ?

The directory is recorded at the beginning of every new tape put onto the NAGRA-D. When a tape is put onto the machine, once a few turns have been wrapped around the take-up reel then the machine will automatically start to wind the tape and will look for the directory. If it does not locate a directory (the tape is virgin) then it will ask the operator (via the LCD display), "FORMAT ?". If the operator presses the EXE key then the machine will format the tape in order to record the directory, this operation takes about 5 - 8 seconds. If the operator presses ESC when the "FORMAT ?" question is on the display then the machine will immediately go into the stop position and the directory mode will be switched off automatically. Once a directory has been recorded it will always be recorded in the same place each time there is a modification. If a tape is formatted in the DIR OFF mode then it is impossible to add a directory to that particular tape at a future date without making a mirror copy of the tape.

In normal operation (directory ON) once the formatting of the tape is completed the machine will sit in the STOP mode ready for the first recording. Each time the machine is put into record, the information about the current take is stored in memory. Whenever the recording session is finished, the operator presses the REW key to rewind the tape and the machine will automatically stop at the beginning of the point where the directory is recorded at the start of the tape and it will stop. To remove the tape from the machine press REW a second time and the machine will immediately record the directory on the tape and will then rewind the tape fully.

NOTE: This procedure of rewind is the same even if the directory mode is OFF but naturally the directory will not be recorded.

WHAT IS IN A DIRECTORY ?

The directory contains the information listed below. A more graphic indication of all the points is covered in the chapter EXTERNAL CONTROL under the NADCOM software.

CONTENTS	BRIEF REMARKS
The tape reel number	(user selectable from 0 to 999)
Up to 350 "drop-outs" per tape	(Input overload and uncorrectable ECC errors)
Duration of the "take"	(minutes and seconds)
Date and time of recording	(according to the internal Real Time Clock)
16 characters for "take title"	(entered from the PC by the user)
Sampling frequency	
Status of the audio inputs	(i.e. 1+2 ANA, 3+4 AES, or copy)
Peak on the inputs	(highest level recorded on each channel)
Fader position flag	(indicating "CAL")
Take time code start	Time only (no frames / user bits)

All of this information is shown on a new screen in the NADCOM program called "Tape Directory Management" which indicates all the above information for each take horizontally, and each line is clearly explained. Each time a recording is made on the tape the above mentioned information will be stored in the machines' memory.

Please refer to chapter 5 of this manual for more information on the NADCOM software.

TAPES WITHOUT DIRECTORIES

If a tape that does not contain a directory, but was previously recorded either with the directory mode OFF or on a machine fitted with a previous version of software that did not have this possibility, then the machine will still load the tape in the same manner and will look for the directory. When it is not found the display will indicate "NO DIR" and the directory mode for this tape will automatically be switched OFF. When recording with the directory mode off, the current take number is still displayed however no skip features will operate.

NOTE: It is not possible to record a directory onto a tape that was previously recorded without one.

TURNING ON/OFF THE DIRECTORY MODE

The directory mode, like many other features of the NAGRA-D, is switched ON via the MENU mode. Pressing the EXE key when ENABLE is on the display in the DIR menu will activate the mode. This is the default mode of the machine. Turning the directory mode OFF is either done in the menu mode (as above) or automatically by the machine if, for example, it detects that a pre-recorded tape without a directory has been put on the machine.

DATA (and SETTING of) FOR THE DIRECTORY

In order for the directory mode to operate correctly, certain information must be set in the machine by the operator. Some of the information is "user" type information such as the reel number, however the most important is the setting of the RTC (real time clock) as it is this information that is used to record the time, date etc. for each reel and each take, and this is totally independent of the internal time code (if fitted).

Setting of all of this data is done in the menu mode by moving to the corresponding display, setting the required values using the down arrow to increment and the right arrow to move to the next digit, followed by ENTER. The take number will automatically be incremented by "1" each time the machine is put into the RECORD mode. The take numbering starts from number "01" and goes up to "99". (take "00" is the directory itself). The take number and reel number may be looked at using the display, the rest of the information in the directory can only be looked at and modified (where possible) via a PC running the NADCOM software.

DIRECTORIES AND HALF SPEED OPERATION

The directories will operate in the same manner for both the normal speed and the half speed modes of the machine. However the machine cannot read the directory if it is set at the wrong speed. If the directory is not read correctly then the message NOTFOUND will appear and the machine will be in the STOP mode. To this message, either EXE meaning RETRY or ESC meaning "OK - too bad" must be pressed. All other transport features will be locked out until this is done. If the machine is not set to the correct tape speed, then the display will indicate "Wrong Spd" the operator can now change the speed and press "EXE". The machine will once again try to read the directory. If this is not the cause and the directory still cannot be read, it is probably due to drop outs or some other deformation of the tape (finger prints etc.). The two tape speeds could be considered as different formats as far as the directory is concerned, a little like trying to read an MS-DOS formatted disk on a MAC !

OPERATION OF THE DIRECTORIES

Under normal operation of the machine, with the directory mode on, there are only a few operations that the operator must be conscious about in addition to his standard procedures. All the rest is pseudo-automatic. In this section we will consider several situations that may occur while using the machine and explain the procedure to be followed.

MAKING A STANDARD RECORDING

Once the machine has been powered up, check that the information in the RTC (real Time Clock) is correct. This

is looked at in the "Otherset" menu. Then select the other settings required for the machine (sampling freq., input selection, time code mode, TC delay etc.). Once the machine is prepared, place a new reel of tape on the supply reel holder, and thread the tape in the normal way. The machine will automatically take up the tape and will automatically go and look for a directory. As it is a new tape, this will not be found. The machine will then return to where the directory should be and will stop. The display will then indicate "FORMAT ?". At this point the operator must reply. No other feature of the machine (transport) will be operational until this is done.

Pressing "EXE" will be taken as a "YES" answer and the machine will automatically switch to the record mode. That is to say, the REC leds will light up on all four channels, and the led above the REC key will also light up. The audio channels will be forced into the ready position (despite the position of the selectors), however the audio inputs will be MUTE, NO time code or CUE track will be recorded. This takes between 5-8 seconds. Once this is complete, the tape is "formatted" and is now ready to be recorded. If necessary this operation can be carried out on several tapes before the recording session starts, and can be considered as the same procedure as is needed to format a floppy disk before it can be used in a PC. Pressing "ESC" will be taken as a "NO" answer, and the machine will automatically switch off the directory mode.

Assuming the tape has now been formatted with a directory, the recording of the tape is now made in the normal way. Each time the machine goes it REC mode and each time it returns to STOP, the information about the "take" (number, time, date, duration etc.) will be stored in the internal memory of the machine. Along with this, there is a great deal of additional information such as the drop-outs, and the input peaks status of the channels to name just a few. More detail is given under the chapter EXTERNAL CONTROL of this manual.

Once the recording is finished, the tape is rewound in the normal way. When the machine arrives at the start of the tape, it will stop, without having completely removed the tape. Pressing REW again now will cause the machine to again switch to record (in the same way as formatting) and it will record the directory (the entire contents of its memory) which takes again 5-8 seconds. Once complete, it will switch to REW and will reel off the tape completely. This can be considered as the "standard" operation for recording a tape using the directory mode, however there will be many cases where this method cannot be adhered to for one or more reasons.

USING THE REC + REW COMMAND

When using the NAGRA-D in directory mode, normally each record start will generate a new directory entry which means that the total of 99 entries can be reached quite quickly if there are a lot of "false starts". It is for this reason that the REC + REW function has been installed. If a false start occurs, the user can start the next recording using REC + REW rather than REC + PLAY and the take will be given the previous take number. In simpler terms, if this command is used, the data from the previous take will be erased from the internal memory and, as far as the directory is concerned, the previous take no longer exists. The actual data that was recorded will of course remain on the tape and if this section is played back the display will indicate " / / " before the counter which indicates the machine is actually between two takes. On the NADCOM display this "gap" will simply not be indicated.

REMEMBER The total number of takes that can be recorded in the directory is 99. If the user goes beyond this, the display will continue to increment 100, 101, 102 etc. but it will flash to indicate to the user that this information will not be stored in the directory. Takes above number 99 cannot be located using the SKIP feature.

PLAYING BACK A TAPE WITH A DIRECTORY

Place the tape on the supply reel holder and laced around the transport. The machine will automatically take up the tape and look for the directory. Once located, it will read the entire directory and store it in its internal memory. Once complete, the machine will stop and await further instructions. As all the "take" information is now in memory, the SKIP features and the GOTO END feature will be operational. Otherwise the normal playback and chase synchronizer operations can be used. At any time during playback the operator can look at the take number in the DISPLAY menu or the reel number in the DIR (directory) menu.

NOTE: Explanation of the data that can be seen on the screen of the PC in the NADCOM software is explained in the chapter EXTERNAL CONTROL of this manual (Tape Directory Management).

WORKING WITH TAPES "TAIL OUT"

There are some applications where there is not enough time to rewind a full reel of tape before the next take and, at the end of a reel, the tape is simply spooled forward and kept "tail out". In this case how does the directory get recorded ? The NAGRA-D will remember the directories of the last 4 tapes that are put on the machine (Three in memory and the fourth on the machine itself). This means that if formatted tapes are used on the machine during the day but are taken off "tail out", then the operator can simply put the tape back on the machine at a later time (when the pressure is off) and the machine will recognize the tape, immediately wind to the correct location and will update the directory from the information stored in its internal memory. The last four tapes used can be done in this manner and no information will be lost. If a fifth tape is put onto the machine (without even pressing REC) the oldest directory in the memory WILL be lost.

NOTE: This information is only remembered as long as there is sufficient power in the internal battery (or during the short period of time used for a battery change). If the machine is left without sufficient power (or the battery is removed for a long period of time) then this information will be lost.

If a tape that is "tail out" (with its already updated directory) is put onto the machine, then the procedure will be as follows. Put the reel on the right-hand reel holder and lace the tape around the transport. Then BEFORE pressing STOP, press REWIND and the machine will go and look for the directory at the beginning of the tape. If STOP is pressed while it is winding to look for the directory, then the machine will stop and will display NOTFOUND. Pressing EXE will be interpreted as "Continue to look" and ESC will be interpreted as "OK Directory OFF". Once the tape has been rewound to the directory at the beginning, it will read it and the tape can then be used as any other.

UPDATING OF A DIRECTORY

There may be occasions when the contents of a directory on a tape need to be modified. Two situations could be

for example:

EXAMPLE 1 A complete tape is made with many different takes, during the day, and later on the names of the individual takes need to be added with the aid of a PC.

EXAMPLE 2 A recording is added to the end of a previously recorded tape.

In example 1 above, the operator would power up the machine and place the recorded tape on the supply side. When laced around the transport, it will automatically be taken-up by the machine and the tape directory will be read. The machine will then rewind to the beginning of the directory and will stop. The information from the directory will be in the memory, and will also be displayed on the "Tape Directory Management" screen of the NADCOM software.

Leaving the machine alone now, the operator can use the PC to add (or change) the names of each take individually (see CHAPTER 5). Once the modifications have been made on the screen of the PC, if the operator now presses REWIND (either on the machine or by means of F3 on the PC, the machine will immediately go into Record and update the directory and will then automatically unlace the tape. The directory on the tape will now contain the modified data.

In example 2 above, the tape is loaded as above and the machine will read the directory. Once this is done stop will automatically be selected. The operator then presses, GOTO END (EXE + REC) and the machine will automatically locate the end of the last take recorded on the tape. The operator can then continue to make recordings on the unused portion of tape. Once this is completed, REW is pressed and the machine will rewind to the beginning of the directory and will then STOP. Pressing REW again, the machine will automatically record the directory and then wind the tape off. The directory on the tape will now be updated with the addition of the new information regarding the added material.

NOTE If the tape directory has been recorded and WRITE PROTECT has been engaged then the directory will not be updated. Remove the protection before removing the tape.

SKIP FEATURES

The addition of the directory mode to the software of the NAGRA-D means that the SKIP features can now be used. Pressing EXE + REW is the "skip to previous take" command, and pressing EXE + FF is the "skip to next take". If skip forward is pressed when the tape is already positioned at the end of the last recorded take on the tape then nothing will happen. Likewise if skip backwards is pressed when the tape is positioned at the very beginning of the reel (before the first take) equally nothing will happen. Pressing EXE + REC will activate the goto end of recording. All of the skip features will stop at a position just before the required point so as to allow a short pre-roll distance. Thus if GOTO END is activated, the machine will park a few seconds before the end of the last recording on the tape. If REC is then pressed the machine will make an assemble edit on the very next track after the end.

INSERT AND ASSEMBLE

The directory mode of the machine is only active in the ASSEMBLE position. That is to say that if an insert is made on a previously recorded tape then this will not affect the data in the directory.

TRACKING

WHAT IS TRACKING ?

The NAGRA-D and some other digital audio tape recorders share their heritage with video recording technology. Video tape recorders have always had a means of adjusting tracking for optimum picture quality. Spinning heads or scanners provide the best means available today to reliably record on tape the immense amounts of data created by the digital audio recording process. Ideal tracking occurs when the spinning playback heads of the scanner travel in the same exact path that the corresponding record head travelled during the original recording.

Under normal circumstances, when working with good tape stocks and properly maintained machines, there is little need to be concerned about manual tracking adjustments. But situations do arise when unacceptable digital noise or the inability to read a tape directory require **TRACKING** adjustment to some setting other than the factory programmed value. Before resorting to manual tracking adjustment, be certain the tape path is thoroughly clean, paying special attention to the ramp of the scanner.

OUT-OF-FORMAT TAPES:

The term "out-of-format" refers to a tape which is recorded in such a way that the diagonal digital-audio-data tracks recorded by the spinning heads of the scanner are not in the proper position on the tape in relationship to reference pulses of the control track, which are recorded by the stationary head at the left of the scanner. The primary purpose of the control track is to enable the Nagra-D's control circuitry to position the digital-audio-data tracks exactly in front of the spinning playback heads.

Why is my tape "out-of-format", what did I do wrong, and who is to blame?

Two common causes for an "out-of-format" recording are dirt and tape debris build-up in the tape path, and worn-out guides. Here are two examples:

1. A bit of sticky adhesive from the tape leader finds its way to the scanner entry guide. This guide, which travels inward each time play or record is initiated, is located just to the left of the scanner. Backing material from the tape begins to accumulate on the guide surface, effectively increasing the diameter of guide. Now, the distance the tape has to travel between the fixed control track head at the left of the dirty guide, and the scanner at the right, is increased. The control track pulses no longer line up correctly with the diagonally arranged digital-audio tracks on the tape. If the machine is recording, the result may be a tape that is recorded "out-of-format". Likewise, if this same guide becomes excessively worn, its diameter is decreased, and the distance between the control track head and the scanner becomes too short.
2. The tape slitting knives at the tape manufacturer have become a little dull/blunt and leave some extra edge debris on tape which finds its way to the NAGRA-D. As the tape moves across the machine's scanner, the dirt begins to pile-up on the right side of the scanner ramp. The ramp is the curved metal ledge, with five screw heads showing, which guides the bottom reference edge of the tape as it passes from left to right across the face of the scanner. The dirt on the ramp lifts the tape up on the right side. The scanner heads are now passing across the tape at the wrong angle. If the machine is recording, the result may be a tape that is recorded "out-of-format". Likewise, if the scanner exit guide edge flanges become worn, the tape may move across the scanner in the wrong position, or the tape may wander up and down.

ALL IS NOT LOST:

Located several button presses away from the NAGRA-D's main LCD time display, is the section of the machine's set-up menu called **Otherset**. This is where the odds-and-ends settings are found. Here, the **TRACKING** feature allows the operator who is familiar with its use, to overcome most performance problems associated with difficulties like those mentioned above. **TRACKING is a playback function**. By over-riding the machine's factory programmed **TRACKING** setting, the digital-audio tracks of a tape which is recorded "out-of-format" can be brought into a correct, or nearly-correct position in front of the scanner's play heads for perfectly acceptable error-free playback.

HOW TO DO IT & WHAT THE NUMBERS MEAN:

Manual tracking adjustment is enabled by selecting **TRACKING** in the LCD display from the **Otherset** section of the menu, then pressing the **EXE** button. Depending on the software version installed in the machine, the procedure varies a little:

Early software:

With software versions prior to Version 2.00, two sets of numbers appear in the LCD window when **TRACKING** is activated. "**T**" is the **tracking number** followed by "**L**", the **level number**. "**T**" is a number between 0 and 255 which simply indicates where the tracking adjustment is set. Think of it as 255 little marks around a potentiometer. The factory programmed number at full-speed will be either 100 or 119, depending on whether the scanner is aligned for half-speed "read after write" or not, meaning that tracking is factory-set just below the middle of the adjustable range. "**L**", a number between 0 and 99, is an indication of the signal strength coming from the tape during play.

When **TRACKING** is activated, the fourth fader knob temporarily becomes the tracking control knob. Turning the knob to the left will cause the "**T**" number to begin stepping downward while turning the knob to the right will make the number increase. The further the knob is moved in either direction from the center, the faster the numbers change. Look for a "**T**" number that produces the highest "**L**" number in the LCD window while listening to playback. This will be the optimum tracking setting for this section of tape. Be certain to return the fourth potentiometer to the center position or the tracking adjustment will continue to change.

Current software:

Beginning with Software Version 2.00, the manual tracking adjustment procedure is simplified and easier to use. When manual tracking is activated, only one number, "**Tr.**", appears in the display. The range of the **tracking number** is 0 to 255 and is temporarily controlled by the fourth fader. The modulometer for channel four temporarily indicates the strength of the signal coming from the tape while the **TRACKING** adjustment is active. "**Tr. XXX**" appears in the LCD window. Rotate the fourth fader until the meter reads maximum signal strength and the playback audio is clean.

Using NADCom to adjust tracking:

When a PC, equipped with **NADCom** software is available for connection to the **Nagra-D**, dealing with an "out-of-format" tape is a simple matter of selecting "**S Miscellaneous settings**" from the Main Menu. Use the computer keyboard Left and Right arrow keys to highlight the **Tracking number**. This is the same **tracking number** which appears in the LCD. Use Page-Up and Page-Down keys to modify the tracking value by steps of ten, then fine-tune by single steps with the Up and Down arrow keys. Watch the **ECC** numbers near the bottom of the screen and adjust the **tracking number** so that the **ECC** numbers are minimum and audio is clean. Pressing "R" on the computer keyboard will restore tracking to the factory-set value.

I KNOW THERE IS A DIRECTORY ON THIS TAPE !

The first several meters of tape at the beginning and end of reels tend to be of marginal quality. Directory data, for reasons mentioned above, can also be recorded "out-of-format". When this happens, the NAGRA-D's LCD may show a message "READ ERR" or "NOT FOUND" after threading a tape. If this situation continues after several attempts to read the directory, press the two arrow keys simultaneously to clear the error message and free the machine for operation. The directory mode has now been temporarily disabled. Press PLAY and proceed to the first area of tape where audio is recorded. Activate **TRACKING** as described above and adjust for the highest signal strength indication with the fourth fader potentiometer. STOP the tape, press the two arrow keys simultaneously to leave the tracking section of the menu, then rewind the tape completely on to the supply reel. Now, load the tape again in the usual way and allow the machine to search for and read the directory with its newly selected tracking value.

NOTE: Do not power-off the machine during this operation or the machine will revert to its default factory tracking value.

ADJUSTING TRACKING AT HALF-SPEED

Half-speed 2-channel recordings on the NAGRA-D tend to be a bit more sensitive to "out-of-format" recordings since the tape is moving slower, control track reference pulses are closer together. Consequently, there is less margin for abnormal mechanical and electronic errors at half-speed.

The factory-set **tracking number** at half-speed is not the same as the full-speed number and is optimized for each individual machine. The half-speed **tracking number** will typically be between 150 and 225, somewhat above the center of the adjustment range. In all other regards, manual tracking adjustment procedures are the same for half-speed operation.

RETURNING TO NORMAL:

After leaving the **TRACKING** section of the menu or after leaving the **Miscellaneous settings** page of the **NADCom** software, the NAGRA-D will retain the last **tracking number** unless the operator manually restores tracking to the factory-set number. So, if you are working with only a small problem area on a tape, be sure to restore the factory-set **tracking number** before proceeding with your session. As a safety precaution, the NAGRA-D will automatically restore the factory-set tracking value the next time the machine is powered up. If you are not sure of the current tracking setting, simply turn the machine off, then back on and tracking will be restored to normal. Manual tracking adjustment has no influence during recording.

DISPLAY MESSAGES

Message	Reason
Cpy. Abort	The STOP key on the master machine has been pressed during the mirror copy operation.
Dir.In mem	When reading, the tape is recognized as having a directory already in memory but not yet saved on tape.
Done	Calibration of speed for SONY control is completed.
End Copy	This will appear when a mirror copy of a tape has terminated correctly.
Erasing	Erasing a tape and directory after a reformat command
FORMAT ?	A virgin tape has been put onto the machine. Pressing EXE will format the tape. Pressing ESC will leave the tape unformatted and will turn the directory mode OFF for the present tape.
Ins. Err.	Mirror copy has been attempted and the SLAVE machine is in the INSERT mode. To correct this, select ASS on the SLAVE machine.
NEWTAPE?	Following the loading process the machine is doubtful as to whether the tape on the machine has been changed. Normally this message will never appear. Pressing ESC will be understood as "same tape" and pressing EXE will be understood as "new tape" upon which the machine will immediately go and read the directory.
No Dir.	No directory has been located on the present tape, or ESC was pressed when the machine was unable to read or write the directory. Press ESC to remove the message, and the machine will continue in the directory OFF mode of operation. This display will not affect the operation of the machine.
NO TAPE	Calibrate mode of the SONY protocol speed has been attempted and no tape is installed on the machine.
NOT DONE	SONY speed calibration procedure not completed (restart).
NO RS 422	This indicates that during the mirror copy function there is a lack of communication between the two machines. Check that the correct RS 422 connection has been made. It may also appear if the slave machine is not fitted with version 2.00 software and a MIRROR COPY is attempted.
NOT RDY	This message will appear in the mirror copy mode if EXE is pressed to start the copy and the destination machine is not ready for some reason. This could appear if for example there is no tape on the machine, or if one of the machines is not in park at the correct place.
NOTFOUND	Directory cannot be located on the tape. Pressing EXE will retry to look for it, pressing ESC will turn the directory mode OFF.
READ ERR.	There has been an error while reading the directory on the tape. Pressing EXE will retry to read the directory, and pressing ESC will turn the directory mode OFF.
Reading	This is displayed during the reading process of the tape directory.
REC. ERR.	An error has occurred during the recording process of the directory. Pressing EXE will retry to record the directory again and pressing ESC will cancel the directory and turn the directory mode OFF. Pressing ESC will not loose the directory in memory.
Rec. Inh.	The RECORD INHIBIT dial switch (N° 1) inside the machine has been set to the ON position. All recording functions are locked out. Set this switch to OFF to record.
TAPE ID.	The ID information at the start of the directory does not correspond with that in memory. Probably the tape has been changed in the middle without updating the

previous directory. Normally this message should never appear if the "rules" at the beginning of this section are adhered to.

- Writing This is displayed during the recording process of the tape directory.
- WRONG LOC. When reading a directory the machine has detected that the tape has a recording but it is looking for the directory in the wrong location on the tape.
- WRONG SPD. When reading the directory the machine has detected that the recording is not at the same tape speed as currently selected. Press the down arrow and the machine will automatically propose the other tape speed. Press EXE to confirm the new selection.
- Wrong Spd. This display indicates that when making a MIRROR COPY of a tape the SLAVE machine is not at the same speed as the MASTER machine.
- Wr. Prot. The current tape is WRITE PROTECTED and a record has been attempted. Remove the write protect command in the directory menu.

CHAPTER 4

SYNCHRONIZATION / REMOTE CONTROL

Synchronization Possibilities	92
General	92
Video Reference	93
Aes Bus Synchronization	93
External Sync	94
Time Code (If Nd-Tc Option Is Fitted)	95
Displaying A Time Code	95
Setting The Time Code (Internal Generator)	96
Selecting The Operating Mode Of The Generator	96
Time Code Assemble Mode	97
Setting Time/User Data From External Or The Keyboard	98
Setting The Time Code Delay	98
Using Nagra-D As Master Time Code Clock	98
Recording A Time Code Signal	98
Replaying Time Code	99
Time Code Synchronization	100
Sync / Sync Incremental	100
Synchronizer Displays	101
Tape Counter	102
Sample Sync	103
Connecting The Nagra-D To An Edit Controller	103
The Protocol	104
Understanding Sony Based Controllers	104
Synchronisation	105
Important Settings In The Editor	105
The Modes / Settings Of The Nagra-D And What They Do	106

SYNCHRONIZATION POSSIBILITIES

GENERAL

Up until now the audio / video domain has always related the word SYNCHRONIZATION with the speed and direction of a tape transport, as is the case with an analogue machine using centre track time code. That is to say that the speed of the transport is directly controlled with respect to an incoming time code signal, and if this time code were to be reversed then the machine itself will reverse. In the case of the NAGRA-D when we talk about synchronization possibilities, we cover all aspects of time code, the use of an external video reference, using the AES bus etc.

If we were to imagine the tape of the NAGRA-D running in reverse (as on an analogue centre track TC machine) the helical scans could not be read by the scanner. Thus in the case of AES bus for example, synchronization is in terms of data form and flow for reasons of compatibility. The AES bus for example can be considered as a synchronized transport for information, whereas a time code signal is transport synchronization information.

All the different synchronization methods are selected on the NAGRA-D by the menu mode. (see MENU's) The diagram below shows the synchronization possibilities of the NAGRA-D each of which will be covered in more detail.

The NAGRA-D can accept the following references:

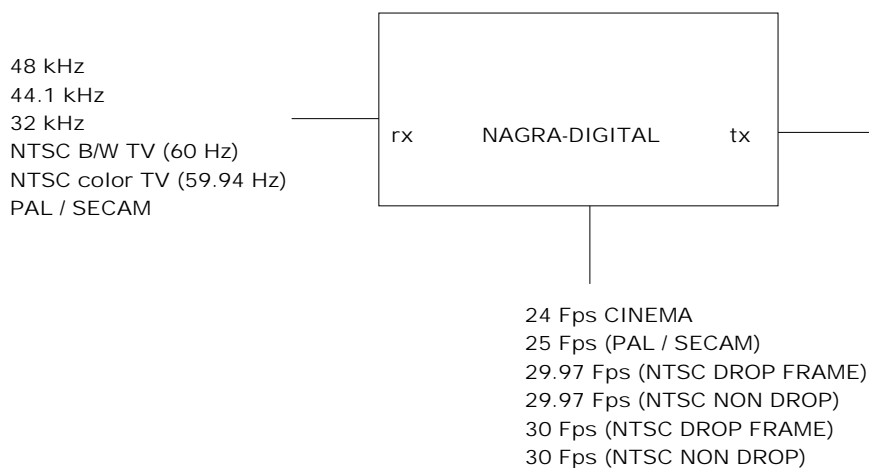

Audio SYNC

The actual connectors for these various synchronization inputs and outputs are located on the sides of the NAGRA-D. The Video and word clock signals are via a standard BNC connector (terminated internally 75 Ohms). The AES synchronization is taken from the AES input (Dig 1+2 or Dig 3+4), menu selectable, on the XLR connectors, the External SYNC is on the 15 pole miniature "D" type connector and the time code is via a 5 pin LEMO connector.

It must be noted that transformation between standards (i.e. 48 kHz IN to 44.1 kHz OUT) is not possible with the NAGRA-D. This could be possible with an external sample rate converter.

VIDEO REFERENCE

Via the BNC socket located on the left-hand side, the NAGRA-D can be fed with composite video signals of the PAL, SECAM or NTSC standards. A composite video signal has the horizontal sync (line sync) just before the burst. This horizontal sync is extracted from the signal by the NAGRA-D and used as a reference for the first VCXO (Voltage controlled crystal oscillator). All the other internal frequencies are in turn referenced to this first VCXO.

NOTE: The presence of an external video signal that corresponds to the selected format is indicated by an "V" (apostrophe) on the display next to the video ref label. If a video reference is selected but is not present then the alarm led will blink.

AES BUS SYNCHRONIZATION

The AES bus permits the synchronizing of stereo signals. As the NAGRA-D operates with 4 channels, a compromise in order to adapt the system to the AES format was necessary. In order to be compatible, the NAGRA-D inserts two channels onto one AES bus line, that is to say channels 1+2 and 3+4 are grouped together, on both the input and the output from the machine, to form two stereo pairs.

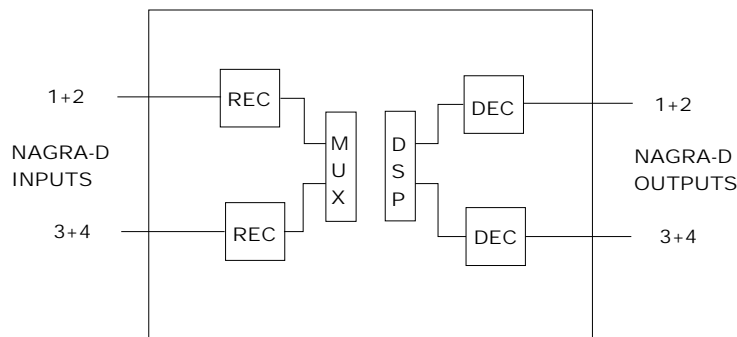

(REC means AES receiver and DEC means AES decoder)

As the scanner rotation speed of the NAGRA-D is 3750 rpm (62.5 rotations per second) then we know that each rotation of the scanner takes 16 mS. As the scanner consists of 2 recording heads (and 2 playback) one track on the tape corresponds to 4 mS. If the track is sub-divided down then there are 4 AES blocks per track. Thus each AES block represents 1 mS of stereo music. If we continue to break down the blocks, we find that each of these AES blocks consists of 192 smaller sub-divisions which are in turn divided in two sub-frames.

Each of these sub-frames contains specific information relating to each channel. Each sub-frame is made up of 32 bits containing 4 sync bits, 24 data bits and 4 auxiliary bits (VUCP). On the data portion of this sub-frame, the NAGRA-D uses 20 bits for the audio and the last 4 bits to record the auxiliary information. The information in the auxiliary has not yet been totally defined in the AES format, presently we only use the "C" and in that we store information such as emphasis (ON or OFF), sampling frequency, stereo/two channel etc. etc.

As with the composite video reference, the AES signal is used as a reference for the first VCXO.

EXTERNAL SYNC

The external sync input is yet another way to synchronize the internal clocks of the NAGRA-D. The advantage of this 5V logic input is that it can be used to control the first VCXO (Voltage Controlled Crystal Oscillator) from an external source without the need of turning the whole input signal into the AES format. (this is very useful in instrumentation). The input can be 32 kHz, 44.1 kHz or 48 kHz or even a remote 9600 baud, depending on the selections made in the REF menu.

This signal can be fed to the machine through the 15 pole miniature "D" type connector.

NOTE: If one of the selections is made and the signal is not fed to the connector then the alarm led will blink.

TIME CODE (if ND-TC option is fitted)

SMPTE/EBU time code has become a standard in film and video applications as an accurate and reliable means of machine synchronisation and sequence location. Location of particular points on the tape in a digital recorder is often done using ID markers, however these do not allow the synchronisation to film or video during post-production.

The NAGRA-D can accommodate all presently recognised formats, these being the following:

24	FPS	-Film applications
25	FPS	-PAL/SECAM Video and film to video applications
29.97	FPS	-NTSC black and white television
29.97	DF	-NTSC colour television
30	FF	-Film applications (NTSC)
30	DF	-Film to video (NTSC)

The time code system of the NAGRA-D also accommodates the standard USER bits in either DATE or FREE modes.

The time code system on the NAGRA-D is equipped with two time code readers (for "external" and "off tape" time codes) as well as an internal time code generator according to the SMPTE / EBU 80 bits longitudinal time code format. It is modulated using the Manchester Bi-Phase technique (a transition during a period represents a "1" and a period without a transition represents a "0"), which is recorded on a dedicated track (see "footprint" in chapter 1 of this manual). The time code system is the only synchronisation mode described in this chapter that will allow the operator to search around the tape. The time code track is a 0.35mm track located just below the control track at the bottom edge of the tape and it is recorded by the longitudinal head. The NAGRA-D is also fitted with an internal chase synchroniser, allowing it to synchronise to any external time code.

The time code input and output is located on a 5 pole LEMO connector, the pinning of which corresponds to that of the IV-STC and T-Audio-TC. The time code system of the NAGRA-D is more complicated than that of the IV-STC or NAGRA T-Audio as it offers possibilities that were not previously available and also requires care on the part of the operator to ensure that the correct information is being recorded and displayed at all times. The QCTCU time code cable delivered with the machine has one point marked "RS 232" this is for the AATON interface for the IV-STC only and should be ignored in the NAGRA-D.

If the RESET HOLD switch is pressed twice in quick succession the display will scroll through the presently selected generator and synchroniser settings, the default values are as follows:

25 fps	(Generator format)
INT. GEN.	(Record source)
FREE RUN	(Generator mode)
SYNC	(Chase mode)
REF. TC.	(Chase reference)
VAR. CLK.	(Sync mode)

DISPLAYING A TIME CODE

The small 8 digit 14 segment display of the NAGRA-D or a PC connected to the RS 422 port can be used to

display time code. If the right arrow is pressed from the normal display position then either the time code playback signal (TC OUT) (replayed from the tape) or TC REC (the time code that will be recorded if the machine is put into record) will be displayed, according to the REC SRC setting (either internal generator or external). The ROLLER (counter roller) or ECC (Error Correction Code) may also be displayed (see DISPLAY in the menu mode). Remember that setting the internal generator will not necessarily change what is displayed if the display is not set to the TC REC position, and the recording source is not set to internal generator. TC DELTA, which is the changing difference between the external reference and the time code on the tape during the synchronising process, can also be displayed.

SETTING THE TIME CODE (INTERNAL GENERATOR)

The internal generator of the NAGRA-D can be set either from the keyboard using the arrow keys, or from an external time code source. Once the internal generator has been set from the EXT source the counting is continued by means of the internal generator, hence there is no need to have a cable link permanently.

KEYBOARD SETTING OF THE INTERNAL GENERATOR

It is important to remember that when setting the time code, the format of the time code must also be set. Once any settings have been executed in the machine these will be remembered even when the power is turned off, as long as there is sufficient power in the internal battery. To set the internal generator from the keyboard proceed as follows:

Press the power key and wait for the machine to scroll through the presently selected menu settings. When this is complete, the machine will indicate the chosen display feature (ROLLER/ECC/TC OUT/TC REC/TC DELTA). The TC OUT and TC REC can be selected to display in either time or user mode. Press the down arrow and the display will indicate TIME CODE. Pressing the right arrow will now move the display into the time code menu and GEN will be displayed, allowing access to all the settings of the internal generator.

SELECTING THE TIME CODE FORMAT (Frame rate selection)

From this point access is given to all the time code functions. Pressing the right arrow from the TIME CODE display will indicate FORMAT, and pressing the right arrow again will indicate the currently selected frame rate. Pressing the down arrow will scroll through the other possibilities in turn. When the desired frame rate is reached press EXE to enter the command. A single beep will be heard to indicate that the command has been accepted and the display will return to the originally displayed option (TC, ROLLER, ECC etc.)

If when entering the FORMAT menu, the desired frame rate is immediately displayed, then it is possible to press both the arrow keys simultaneously (ESC) to exit without making any modification.

SELECTING THE RECORDING SOURCE (INTERNAL generator or EXTERNAL or ASSEMBLE)

From the FORMAT display, press the down arrow and the display will indicate REC SRC allowing the selection of the time code source to be recorded, (either from the internal generator or from an external source) or time code assemble mode. Simply press EXE to select the desired source when displayed. When the ASSEMBLE is selected and the machine is set to record, a seamless time code assemble will be performed.

SELECTING THE OPERATING MODE OF THE GENERATOR

From the FORMAT position press the down arrow twice and the display will show GEN MODE. When pressing the right arrow now, the operator can select the operating mode of the internal generator for either the time portion of the signal or the user part. For the TIME portion the two possibilities are FREE RUN and REC RUN.

Free run means that the time code generator will count continuously, according to the selected frame format. Thus allowing the user to work with "time of day" or "sequential" time code. In the REC RUN (record run) mode, the internal time code generator will only run when the machine is in the record mode. As soon as the machine stops recording then the internal generator is frozen and will remain that way until the machine is put into record again. This allows "continuous" time code recording along a tape. For the USER portion of the signal, there are four different modes that can be selected. The most important selection here is between the DATE or FREE positions. The user bits must be in the same format as the external source if setting is to be made in either direction. The other two possibilities for the user bits are FREE INC or DATE INC. These two are essentially the same as the normal date and free modes except the right-most two digits are automatically incremented by one, from 00 to 99, each time the machine is put into the record mode.

TIME CODE ASSEMBLE MODE

How to start a tape - Select ASSEMBLE then SET TIME (or RESET) which will force and freeze the internal time code generator at the value previously selected. This will also put the USER BITS mode according to the selected mode (DATE or FREE). When the machine passes on record the time code will immediately start to count from this value. From this point on, each time the machine is put into REC mode a full time code assemble will be performed, by reading the last recorded time code value on the tape during the PRE ROLL. The USER BITS will also be assembled in the same manner and incremented automatically if the machine is in the INC USER mode.

If a CRASH RECORD is made (no time code read during PRE-ROLL) then the recording will start from the roller updated last read value.

NOTE: When setting the time code in this mode, this does not actually affect the TIME portion of the internal RTC. However if the USER BITS are set, then this will change the settings of the USER DATA in the RTC. The USER DATA can only be changed when the time portion is frozen. If in the DATE mode then the date will only be updated at midnight in the FREE RUN MODE.

SETTING TIME/USER DATA FROM EXTERNAL OR THE KEYBOARD

From the FORMAT position press the down arrow three times and the display will then indicate SET GEN. Moving to the right now, the display will indicate FROM EXT. If EXE is now pressed the time code will be JAM synced from an external time code, and the display will return to the selected display mode. If however the down arrow is pressed then SET TIME will be displayed. Moving to the right will indicate the time portion of the code with the left-most digit flashing. The down arrow key will now increment the flashing digit. Pressing the right arrow will move to the next digit. Continue in this manner until the desired time is indicated and then press EXE. Remember that the time code entered must correspond to the frame rate that has been selected in the FORMAT setting. Thus if the machine is in 24 FPS mode then entering a time code of 10.55.25.27 will not be accepted. From the SET TIME position press the down arrow and the display will indicate SET USER. Proceed in the same manner as above to set all the USER bits. Remember that the format of the user bits must correspond to the format selected in the USER MODE selection. All dates must correspond to the DD.MM.YY.xx format. The free user bits may be programmed in HEX from 0 to F for each of the 8 positions.

SETTING THE TIME CODE DELAY

The time code delay selection is a new feature that was not installed in previous NAGRA time code products. Due to the difference in time needed to process digital and analog signals, either from the inputs or on the outputs, it is necessary to reference the time code system according to the operation being made. That is to say that if a digital input signal is being recorded then the time code needs to be referenced to the AES input, so that exact synchronization can be guaranteed during replay. Thus the possible settings for this are either ANALOG or AES for both INPUT and OUTPUT.

USING NAGRA-D AS MASTER TIME CODE CLOCK

First set the internal time code generator as described above. Then move down through the menus until GEN OUT is displayed. When EXE is pressed the internal time code generator is fed to the time code output and can then be used to set external equipment. It will remain on the output connector until a transport key is pressed, and will then revert to the time code playback signal.

RECORDING A TIME CODE SIGNAL

Set the RECORDING SOURCE in the menu mode to the desired setting and if necessary set the internal time code generator as described above. Check that the tape to be recorded is a new tape and that the INS/ASS switch is in the ASS position. It is not possible to record time code after the audio has been recorded as the time code signal will interfere with the control track already on the tape.

In the MENU mode, set the DELAY to INPUT and then either analog or digital depending on the audio inputs being used. This position is the reference point for the time code, in order to compensate for the delays in digital processing of the audio signals. Set the time code lock out switch to the READY position and then put the machine into the record READY mode on the desired pair of channels. The time code will be recorded according to the mode of the generator (Free run or REC run).

REPLAYING TIME CODE

Place the tape to be played back on the machine, and press playback. The time code from the tape can now be read on the time code output connector, and can also be seen on the display providing it has been set to time code PLAY position. In the MENU mode, set the DELAY to OUTPUT and then either analog or digital depending on the audio outputs being used. This position is the reference point for the time code, in order to compensate for the delays in digital processing of the audio signals.

It should be noted that during winding modes, the time code from the tape is read directly wherever possible. However if the winding speed of the tape is set to 4 m/s and the tape was recorded in the half speed two channel mode then, during rewind, the tape is at more than 80 times nominal speed which is too fast to read and process the time code coming from the tape. In this situation, the time code on the output connector will be driven by the counter roller and will only be verified when the speed of the machine slows down to a speed where the time code is readable.

As the longitudinal speed of the tape on the NAGRA-D varies depending on the sampling frequency selected, then for time code to be played back correctly the machine must be at the same sampling frequency as during the recording. If the machine is not at the same sampling frequency as the recording, then the flag 1 will be indicated on the main LCD display. This is important when copying tapes.

TIME CODE SYNCHRONIZATION

The time code version of the NAGRA-D is fitted with an internal time code chase synchroniser. The synchroniser performs in much the same way as the internal synchroniser of the NAGRA T-AUDIO TC. It has the possibility to synchronise the machine either to an external time code that is fed to the LEMO connector on the left-hand side of the machine, or to a video sync reference fed to the BNC connector.

Chase synchronisers in the digital domain are not as simple to understand as those used in analogue machines. If, for example, the machine is synchronised to a reference that is not at the correct speed, then the digital outputs of the machine will not be at their correct sampling frequency which will cause problems during digital transfers. It is for this reason that the internal synchroniser of the NAGRA-D has two different operating modes. One is called the VAR CLK (variable clock) (VCLO) mode and the other is the FIX CLK (fixed clock)(VCXO). In the first instance the machine will lock its VCLO to the incoming time code and the digital outputs may have jitter etc. rendering them unusable. In the latter mode of synchronisation, once the correct sync point is reached and the machine is locked, then it will automatically switch over to the internal crystal as its reference allowing the digital outputs to be used. At present, the only way for the machine to make the "slow down" needed in NTSC to synchronise the machine at 59.94 Hz (NTSC colour) as opposed to 60 Hz (NTSC black and white) is to use the VCLO option #10200.

The actual operation, and explanation of the synchroniser terms are covered in the MENU chapter under the heading TIME CODE. The internal synchroniser of the NAGRA-D is activated, according to the pre-selected modes, by pressing the PLAY, FF and REW keys simultaneously. While the machine is not sync locked, all three of the leds above these keys, as well as the RDY led, will flash. When the transport is locked, then all these leds will be ON permanently and the apostrophe (') on the display opposite the "lock" will be on.

In the MENU mode, set the DELAY to OUTPUT and then either analog or digital depending on the audio outputs being used. This position is the reference point for the time code in order to compensate for the delays in digital processing of the audio signals.

SYNC / SYNC INCREMENTAL

When making a time code synchronisation two possible modes are available. In both case the synchroniser is put into operation by pressing PLAY + REW + FF simultaneously:

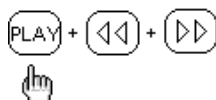

- SYNC: The time code reference fed to the LEMO connector on the left side of the machine corresponds exactly to the time code on the tape (unless an offset has been programmed)
- SYNC INC: The time code on the tape and fed to the input connector are not the same. A new offset will be calculated automatically each time the chase command is selected.

SYNCHRONIZER DISPLAYS

Several indications are made on the LCD display while using the time code synchronizer, these are explained below:

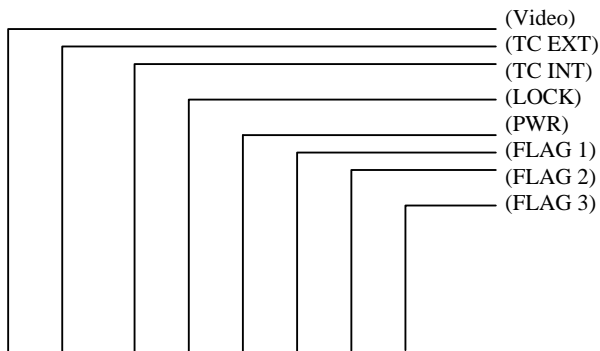

The (') indications between the digits will light up under certain conditions which are:

- | | |
|--------|--|
| VIDEO | When alight this indicates that a valid video reference is present on the BNC connector, either PAL or NTSC (for the time code only) the video reference if used, must correspond to the time code (ie PAL = 25 Fps TC). |
| TC EXT | When alight this indicates external time code is present and is being correctly decoded by the time code circuit. |
| TC INT | When alight this indicates that time code is being read from the tape and is being correctly decoded by the time code circuit. |
| LOCK | When alight this indicates that the internal synchronizer has locked the transport to the external reference, according to the synchronizer and reference. |
| PWR | When alight this indicates that an external source is connected to the machine and that the internal battery is being charged. |
| FLAG 1 | Sampling Frequency on tape not the same as that of the machine. (will not indicate in the EE position) |
| FLAG 2 | Not presently used |
| FLAG 3 | When alight this indicates that the internal time code synchronizer sync mode is set to VCLO (VAR CLOCK). |

TAPE COUNTER

The tape counter roller is the default display mode for the machine. The counter indicates in hours, minutes, and seconds, and is driven from the left-hand tension roller. The counter can be selected to be displayed by pressing the right arrow and then the down arrow until ROLLER is shown, followed by the EXE key.

The tape counter can be reset to zero at any moment (even during recording) by pressing the EXE + RDY keys simultaneously. If the EXE + STOP keys are pressed together this will activate the GOTO ZERO feature. This mode does not operate in the REC mode.

NOTE: Under RS 422 SONY protocol control the counter roller (CTL or Timer 1) mode for synchronisation must not be used as the definition of the roller on the NAGRA-D is not high enough to allow accurate synchronisation. If this is the case then the editor will not be able to synchronise the machine.

SAMPLE SYNC

With the version 2.00 (or higher) CPU software, providing the machine is equipped with the ND-TC time code option and the clock board eeprom is version 2.00 and a modification to the CUE circuit has been made, then the sample sync option will operate. Machines with serial number 1001007 and higher have already been modified for the sample sync possibility, in the factory prior to delivery.

This feature allows two NAGRA-D recorders to be locked together with sample accurate synchronization during record. Likewise, during playback the two machines can be synchronized giving eight channels in perfect sync.

Naturally this option can be used for machines that are running external converters sampling at 96 kHz (if the ND-HSF option is installed) and thus giving 4 channels at 96 kHz.

For the sample sync feature to operate, not only a special cable needs to be used between the two machines, but the machine needs to have a small electronic modification to bring the 1 per revolution signal from the clock board out to the Extension connector on the left side of the machine. Machines from serial number 101007 onwards are already modified for this option. Please contact your nearest agent if you need this modification. (This modification is explained on Technical Information sheet TIE 10-25).

Once a recording is to be made in this mode, connect the two machines together using the extension connector. In the REF FREQ menu, select SAM. SYNC on the slave machine. Set the time code REC. SRC. to TC EXT and make sure that the time code format frame rate is the same on both machines. All other settings such as time code delay are set in the normal way, according to the inputs being used. If the sampling frequency of the two machines is not the same then the alarm led will flash. Simply start both machines in record in the normal way. Remember this will only operate if time code is recorded at the same time as the audio.

When such a recording is to be played back, simply use the internal time code chase synchronizer to lock the two machines together in playback. Once again set the REF FREQ setting of the slave machine to SAM SYNC, and the synchronization reference of the time code to REF TC and make sure that there is no OFFSET in the time code offset memory otherwise the sample sync will not work correctly.

It should also be pointed out at this point that the FIX / VAR clock settings have no function in this mode and that all speed variation of the machines is forbidden.

NOTE: If during recording the ALARM led flashes during the recording process. This will indicate that the sample sync has been lost and that it will not re-synchronize before the end of the recording in order to avoid damaging the current recording.

CONNECTING THE NAGRA-D TO AN EDIT CONTROLLER

As the NAGRA-Ds tape format is unique, tapes made in the field using a NAGRA-D can only be replayed on a NAGRA-D in the studio for post production work.

It is very difficult to explain exactly how the post-production should be done, as there are so many different practices used around the world. The aim of this section is to explain the various points to which attention should be paid and to go through the various different settings used in a STANDARD post production environment.

From these explanations, the user should be able to adapt the settings according to his particular environment.

THE PROTOCOL

If the NAGRA-D is to be controlled externally in a post-production environment, the ND-422S option (#10210) needs to be installed on the machine. The option is a software option that can be ordered from your nearest dealer. In order to install the option on the machine, a PC equipped with the NADCOM software needs to be available.

To determine whether the protocol is installed on a machine, go to the OTHERSET menu and then move through this menu until you come to the RS 422 menu. Move to the right to the SLAVE position then right again. If the word AUTO / SONY or AMPEX appears on the display, then the SONY option has already been installed on the machine.

For external control of the NAGRA-D, the SONY 9-pin serial remote control protocol is used. Under normal circumstances the NAGRA-D will automatically recognise a SONY based editor control protocol and will automatically select this mode for the RS 422 communication.

When the RS 422 lead has been connected to the NAGRA-D the standard transport functions from the editor such as STOP, PLAY, FF, REW etc. should be immediately active.

UNDERSTANDING SONY BASED CONTROLLERS

In order to be able to correctly use a NAGRA-D (or any other audio machine) in a post production environment, it is important to have a general understanding of how controllers operate. This general knowledge will enable the operator to localise problems and have a better idea of where to look for the cause in the event of difficulties in controlling the NAGRA-D.

The SONY 9-pin remote control protocol was initially designed for controlling SONY video recorders from SONY editors. Over the years, this protocol has been adopted by numerous manufactures as a control protocol. This protocol has many different ways of performing the same task and different manufacturers use different commands to do the same thing. Interpretation of such commands is sometimes the cause of difficulties.

As a simple example of this: the majority of machines today are cassette based and therefore the command "EJECT" is perfectly understandable. However a NAGRA T-Audio, NAGRA-D or BVH 2000 for that matter, have open reels. On all of these machines the command EJECT is interpreted as "UNTHREAD". Another example of such differences would be the command "JOG at speed ZERO". Is this the same as PAUSE ?

The NAGRA-D tries to respond to commands as we think is appropriate. However, it may be that with certain controllers, small anomalies occur that will need to be addressed.

SYNCHRONISATION

Unlike video recorders (or DAT machines) in general, NAGRA recorders have a built in CHASE synchronizer. This means that the machine is an "intelligent transport" and is able to perform tasks unaided such as "Chase to a time code coming from a VTR". However, as most machines in studios today are unable to do this, it is the editor that does all the work. Naturally, the NAGRA-D (or T-Audio) is better at handling its ballistics than an external controller made by another company.

This too can be a source of potential problems when setting up an edit controller.

A SONY based editor performs the job of the synchroniser inside the NAGRA. So instead of sending a "synchronise" command, it will send a series of transport commands, such as "+10% speed" or "-5% speed" to get the machine to the correct frame and will then send a PLAY command. The NAGRA-D has two different ways of interpreting this command, depending on the reference selected. If REF TC is selected then the command will be accepted as a normal PLAY command and the machine will be "Locked" somewhere within the frame previously selected by the editor. If the REF FRAME PULSE is selected then the PLAY command will be interpreted as "PLAY LOCKED TO THE VIDEO REFERENCE" and at this point the NAGRA-D's internal synchroniser will move the transport back or forward to synchronise the time code to the Video sync burst. This procedure can take a couple of seconds during which time the editor may abort as the NAGRA-D does not indicate LOCKED. However if the editor allows this, then it is a much more accurate synchronisation.

IMPORTANT SETTINGS IN THE EDITOR

There are some settings in the editor which can cause problems for the NAGRA-D as far as the synchronisation process is concerned. These settings may differ in name from one editor to another but generally an operator will be familiar with such settings:

- | | |
|-----------------|--|
| TIMER 1 | The Timer 1 setting may be known as CTL (Counter) or ROLLER. It is used in Video recorders to synchronise the transport in the event that time code is missing or not available. The counter roller of the NAGRA-D is NOT ACCURATE ENOUGH to allow the machine to be synchronised on CTL. So the edit controller MUST be set to Time code synchronisation. |
| PRE-ROLL | In a normal editing situation, the picture is always MASTER and the sound simply follows. As a result, the editor will move the video machine until it is in the correct frame. Only at this time can the NAGRA-D synchronise itself. As a result, generally a 5 second pre-roll will not be sufficient for the NAGRA-D to be synchronised reliably at the "IN" point. A SEVEN second Pre-roll is recommended. |
| IDENT | True SONY editors will not recognise a NAGRA-D as a specific machine with its own set of commands. In this case the NAGRA-D needs to be set to BVU-800 position in the RS 422 menu which is used as the "generic" command protocol. Editors that allow different sets of commands to be stored for different machines may operate better if such commands are stored as NAGRA-D ballistics. In such a case, the NAGRA-D position should be selected. |

THE MODES / SETTINGS OF THE NAGRA-D and what they do.

OFFSET	This concerns only standard time code chase synchronisation and is of no importance when using the SONY protocol. It is the difference between the time code on the audio tape and the time code reference. This can be set manually by the user in the OFFSET menu, or it will be calculated automatically if SYNC INC is used. BEWARE: An unwanted offset in the memory will affect accurate synchronisation. Resetting the offset is necessary by executing the RESET position.
CHASE MODE	
<i>SYNC</i>	In this mode, the time code on the tape and the time code reference must be the same. (Offsets can be programmed manually if necessary)
<i>SYNC INC</i>	In this mode, a new offset will be calculated automatically each time the SYNC function is activated (FF+REW+PLAY).
<i>REF TC</i>	The machine will synchronise to time code rather than video clock when editing. All PLAY commands coming from the editor will be understood as normal PLAY.
<i>REF FR.P.</i>	The machine will synchronise to the clock video on the BNC connector rather than time code when editing. All PLAY commands coming from the editor will be understood as PLAY+SYNC to reference (or CHASE). The machine will be LOCKED to the video frame.
DISCONT	Discontinuity handling should not affect the synchronisation process and is used once the machine is locked to run smoothly over any discontinuities in the time code.
REAC.TIME	This is the reaction time of the synchroniser or, more accurately, the number of frames that will pass before the synchroniser detects a problem (default is 15 frames).
REF.FREQ	This is the external reference for the internal clocks of the NAGRA-D. It is the reference signal for all the internal timing pulses. When in video applications and under editor control, this MUST be set to the incoming VIDEO reference.
(optional) <i>CRYSTAL</i> <i>VCLO</i>	Normal operating mode with external reference within 100 ppm.. Operation using an external reference of +/- 1% .Used for slowing down from 30 to 29.97fps (60 to 59.94) in NTSC countries while keeping the digital outputs of the NAGRA-D operational.

SYNC MODE

FIX CLK

In the FIX CLK mode the machine will always follow the external reference. Once the machine is in the LOCKED state the internal synchroniser will no longer influence the transport and the transport speed is controlled entirely by the reference frequency (REF FREQ menu). If however the synchroniser of the NAGRA-D sees an error of more than 1 frame, it will re-engage itself to correct the synchronisation error. This is the recommended operating mode.

VAR CLK

This mode is designed to allow the machine to follow an external reference that is not the same as the REF FREQ using the internal synchroniser. This setting allows the internal synchroniser to modify the internal clocks in such a way as to follow this REF FREQ (for example NTSC / NTSC 60). In this mode, the digital outputs are not available and the quality of the analogue outputs may be slightly degraded. Such a situation arises when the tape has 30FF time code and the external reference is NTSC (59.94). The machine will slow the tape down to 29.97 FP

CHAPTER 5

NADCOM

Nadcom Software	109
Installation Of Nadcom Software	109
Main Menu Screen.....	110
A Analog Measures	112
C Interactive Control Panel.....	114
D Audio Settings	115
F Feature Settings	116
L Tape Directory Management	117
M Time Code Menus	120
N User Name Setting.....	121
R Ecc Error Report	122
S Miscellaneous Settings.....	123
T Time Code Counters	124
V Tape Speed Override	125
Q Quit	125

NADCOM SOFTWARE

The NAGRA-D is fitted with an RS 422 port giving direct access to the main microprocessor. The communication protocol of the machine is a NAGRA protocol based on the existing AMPEX protocol. That is to say that the NAGRA-D will operate under the AMPEX protocol but will also allow access to many features that the existing standard protocol does not. The standard AMPEX protocol is made up of two "pages" of commands. These can be considered as 1 and 1a.

Presently the protocol operates with the NAGRA-D from a PC. This software is delivered on a High Density Double Sided 3 1/2" diskette, and requires a PC of 286 or better in order to operate. The PC is connected to the NAGRA-D via the ND-PCA (#10540) RS 232 / RS 422 adapter. A standard PC is not normally fitted with an RS 422 serial port. This adapter simply converts the standard RS 232 port into an RS 422 port compatible with the NAGRA-D.

INSTALLATION OF NADCOM SOFTWARE

Connect the NAGRA-D to the PC via the accessory ND-PCA and copy the diskettes' contents into a sub-directory of the PC's hard disk "C:\NADCOM". The NADCOM software defaults to operate through the communication port COM2. If the PC is only fitted with one serial port this will probably be COM1. Thus, in order to launch the program, type the following command: NADCOM -PCOM1. This tells the PC to use the communication port COM1.

NOTE: The NAGRA-D must be in the SLAVE position in order to communicate with the PC (see OTHERSET MENU)

The PC will now display the main menu of the NADCOM software. The top right-hand corner of the screen will indicate OK if the correct communication is established. Otherwise KO will be flashing in RED.

Launching the NADCOM by typing either NADCOM -h or NADCOM -? will indicate the options.

On certain screens it is possible to move from one selection to another. This is done by pressing either the right (or left) arrow keys or alternatively the TAB key. The up and down arrows on the keyboard are used to change values where possible.

The NADCOM software can also be run from the diskette if for some reason the user does not wish to install it onto the hard drive.

NOTE: The NADCOM software is a DOS based program, and was not designed to operate under windows. It is therefore recommended to exit from windows before running the NADCOM software.

MAIN MENU SCREEN



Permanently, when using the NADCOM software the function keys of the PC are reserved for the main transport features of the machine. They can be accessed at any time and they are described individually below:

- F2: TAPE Below the F2 key, the current status of the TAPE/EE switch is indicated. If the position of the switch is changed then the indication will be either TAPE or E/E. If the position is in the AUTO mode then the display corresponds to the mode of the machine. (see MENU mode). Pressing the F2 key will override the switch setting on the machine itself and will toggle between TAPE and EE.
- F3: REW This is the REWIND command which will put the machine into rewind according to the winding speed selected in the OTHERSET menu.
- F4: FF This is the FAST FORWARD command which will put the machine into forward wind according to the winding speed selected in the OTHERSET menu.
- F5: PLAY This is the standard PLAYBACK command for the machine.
- F6: STOP This is the main STOP command.
- F7: REC This is the RECORD key that will put the machine into the record mode according to the positions of the READY SAFE keys on the main control panel as well as the corresponding INPUT settings in the menu mode. It should be noted that on a colour screen this is indicated in RED and on a monochrome display it is underlined. This indicates that it is a shifted function, and the shift key must be held down in order to activate this feature. This is done simply to avoid the machine being accidentally put into the RECORD mode.

- F8: RDY This is the scanner on key (READY) and will start the scanner if pressed. The scanner will run for 1 minute and then stop again if no other feature is activated.
- F10: EXIT When in any sub menu of the NADCOM the F10 key will return to the main menu. From the main menu screen simply press "Q" QUIT to leave the program.

NOTE: The selected function is indicated in **BOLD** print when activated.

On the center of the screen there are 12 possible sub menus that can be activated by simply pressing the corresponding letter. Each of these is shown and described on the following pages.

Above the function key displays, there are three lines of additional information that are present all the time. Firstly the DSP1 and DSP2 indications show that 192 sectors per track are present (for each pair of tracks, followed by the " / " and the number of errors detected on each pair of tracks in the above case there are no errors.

On the next line, the present status settings of the inputs and outputs of the machine. In the case shown Inputs 1 + 2 and inputs 3 + 4 are both set to ANALOG. The outputs of the machine are 48 kHz AES and between the "[]" the letters NN indicate No emphasis on any channel. When a tape is being played back, these two last indications show the sampling frequency that is recorded on the tape irrespective of the present sampling frequency setting of the machine.

The third line of the status information shows the current transport mode of the machine (NO TAPE in the case shown). To the right of this is the counter roller value (or time code output if ND-TC option is fitted), which is shown in hours minutes seconds and frames. Beyond this, inside "[]s" are AMPEX status indications:

- P=PAL
- N=NTSC
- D=DROP FRAME
- T=TIME LINE RUNNING
- F=DEFERRED BUFFER FULL
- E=CURRENT EVENT EXECUTING Not yet implemented
- L=LOCAL EVENT EXECUTING Not yet implemented
- R=REMOTE EVENT EXECUTING Not yet implemented.
- ?=DOWNLOADING REQUIRED Not yet implemented
- !=EDIT ERROR Not yet implemented

To the right of the status indication is the present operating mode of the machine. In the case shown FULL SPD (4 channel operation), 48 kHz sampling frequency, MASTER clock internal reference and LOCKED (to the reference, in this case, the internal crystals of the machine).

Above the main commands window there is one line of information at the top of the screen indicating the Version and date of the NADCOM program, the serial number of the NAGRA-D connected (in this case the machine 1000426), followed by the name of the owner that has been programmed (in this case KSA DEMO) and the version and date/time of the EPROM installed on the main CPU board (v1.06). Finally in the top right-hand corner of the screen is the status of the communication between the PC and the NAGRA-D this being either OK (when all is working) or KO (in RED) will flash (if the machine is not communicating).

A ANALOG MEASURES

If "A" is pressed the ANALOG MEASURES are displayed. This page indicates many voltages, currents and other information about the machine, and is updated periodically depending on the state of the machine. Each measurement is listed and explained below. Some of these are very useful to the user, and some are purely for use within the factory. This page is generally used for diagnostic purposes, to help locate possible problems within the machine.

NADCom					
NADCom 1.6 (Apr 8) NAGRA-D [1000426] "KSA DEMO" v01.06 14/04/94 15:58 OK					
Analog Measures					
CapsSpeed	11.20	IBat	+0.115A	P110L256	99.9%
CapsPhase	11.10	I12	0.4A	P11800	50.5%
CapsLed	1.50	I15	0.6A	P11175	0.2%
ScanLed	1.60	I5	0.9A	P1114	52.5%
ControlTrack	5.00	VCaps	+0.40	P1196	60.8%
TensR	2.80	UScan	+1.00	Vclo14Present	0
TensL	6.20	VRee1R	+1.00		
ReelsUDR	1u	VRee1L	+0.10		
ReelsUDL	1u	ICaps	7.3mA		
ReelsLedR	0.80	IScan	1.0mA		
ReelsLedL	0.50	IRee1R	0.0mA		
ICarriage	49mA	IRee1L	0.0mA		
Carriage	8.50	Fade1	-3.9°		
UBat	13.50	Fade2	-1.1°		
V15	15.40	Fade3	-0.6°		
V12	12.00	Fade4	+0.6°		
V5	5.30	P110X256	54.5%		
DSP1: 192.0 sectors / ECC 0.0 DSP2: 192.0 sectors / ECC 0.0					
In.12: Analog In.34:Copy 12 Dig.Out.12: 48K[MM] Dig.Out.34: 48K[MM]					
STOP 12:50:32:04 [P L] Full Spd 48KHz Ck.Ref.: Master LOCKED					
F2	F3	F4	F5	F6	F7
E/E	REW	FF	PLAY	STOP	REC
				F8	F9
				RDY	COOKED
					F10
					EXIT

The values may change slightly from machine to machine, also depending on the current operating mode of the machine, and therefore these values shown should not be taken as the absolute values. However they should be approximately the same as any other machine.

The meaning of each position is explained on the following page.

EXPLANATION OF THE POSITIONS

CapsSpeed	Capstan speed represented in Volts.
CapsPhase	As above but for the phase measurement.
CapsLed	Voltages of the LEDS inside the capstan motor. Used to detect deterioration of the condition of the leds.
ScanLed	As above but for the scanner motor.
ControlTrack	Level of the control track.
TensR	Position of the right-hand tension arm. when in the central position.
TensL	As above but for the left-hand tension arm.
ReelsUDR	Direction of rotation indication of the right-hand reel motor.
ReelsUDL	As above but for the left-hand reel motor.
ReelsLedR	Internal leds of the reel motor (see CAPSLEDs)
ReelsLedL	Internal leds of the reel motor (see CAPSLEDs)
ICarriage	Current being drawn by the carriage motor.
Carriage	Voltage indication relating to the position of the carriage.
VBat	Voltage of the internal battery.
V15	Measurement of the 15V line within the machine.
V12	Measurement of the 12V line within the machine.
V5	Measurement of the 5V line within the machine.
IBat	Current being supplied to, or drawn from the internal battery.
I12	Current being drawn on the 12 volt line.
I15	Current being drawn on the 15 volt line.
I5	Current being drawn on the 5 volt line.
VCaps	Voltage on the capstan motor.
VScan	Voltage on the scanner motor.
VReelR	Voltage on the right-hand reel motor.
VReelL	Voltage on the left-hand reel motor.
ICaps	Current being drawn by the capstan motor.
IScan	Current being drawn by the scanner motor.
IreelR	Current being drawn by the right-hand reel motor.
IreelL	Current being drawn by the left-hand reel motor.
Fade1	Rotational position of the fader nE1 indicated in degrees.
Fade2	Rotational position of the fader nE2 indicated in degrees.
Fade3	Rotational position of the fader nE3 indicated in degrees.
Fade4	Rotational position of the fader nE4 indicated in degrees.
PIIVX256	VCXO (256 times sampling freq) PLL.
PIIVL256	VCLO (256 times sampling freq) PLL.
PII800	RF clock PLL.
PII175	Video sync PLL.
PII14	Crystal correction PLL.
PII96	DSP serial clock PLL.

It should also be noted that the function keys F9 and F10 are also activated in this mode.

F9: COOKED indicates that all the above values have been treated and are indicated in Volts etc. If F9 is pressed then the word RAW will appear and all the above values will be indicated in their Hexadecimal value.

F10: EXIT - This key is used to return to the main menu.

C INTERACTIVE CONTROL PANEL



When the "C" is pressed from the main menu the screen will switch to the interactive control panel. This screen gives an "LCD style" bar graph indication of the 4 modulometers in the top left-hand corner, the present operational mode of the machine in the top right-hand corner and a display of time code (UB or OFFSET) below. The indication of the time code display is indicated by the highlighted term above. It can indicate TC OUT, UB OUT, TC EXT, TC REC, UB REC or OFFSET. Simply use the "TAB" to change the highlighted choice. This interactive control panel can be considered as a long distance viewing screen.

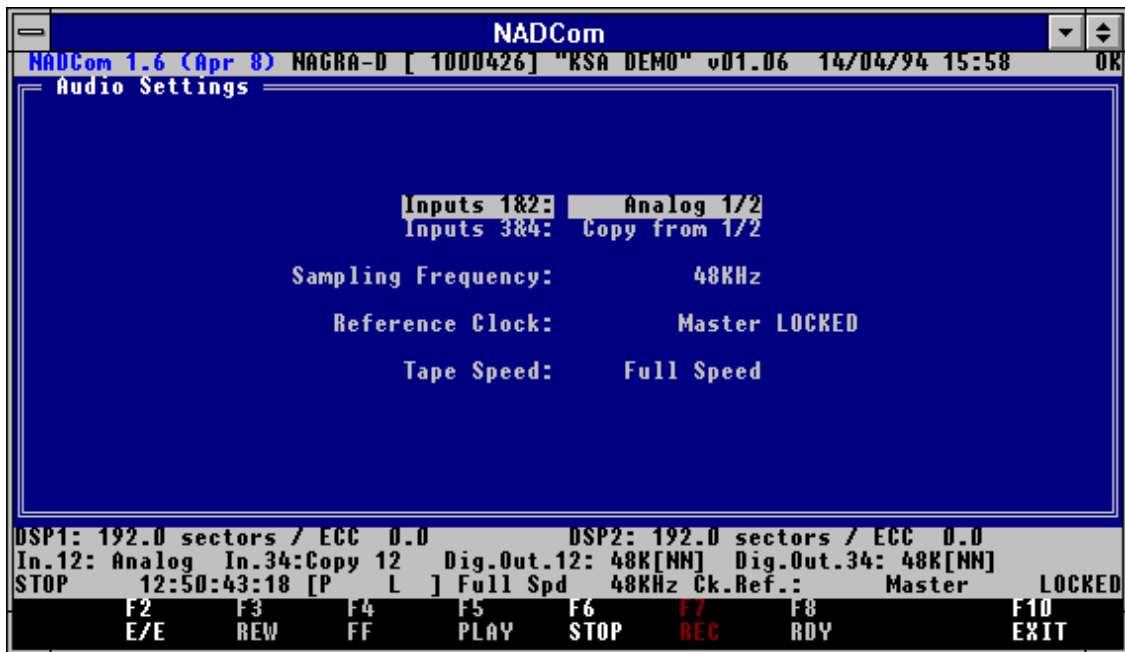

D AUDIO SETTINGS

The aim of the AUDIO SETTINGS screen is to give the user access to the rest of the user selectable menus, without the need of going through all the menus on the display of the machine. It allows access to the Input configuration for the two pairs of inputs, in the case shown inputs 1 and 2 are set to ANALOG and inputs 3 and 4 are set to copy 1 and 2. It also gives access to the sampling frequency of the machine (presently 48 kHz). Access to the REFERENCE frequency for the internal clocks is also given The last position is the tape speed (presently FULL SPEED).

In order to move around this screen from one selection to another, simply press TAB and then the UP arrow (or DOWN arrow) keys to change the presently selected values.

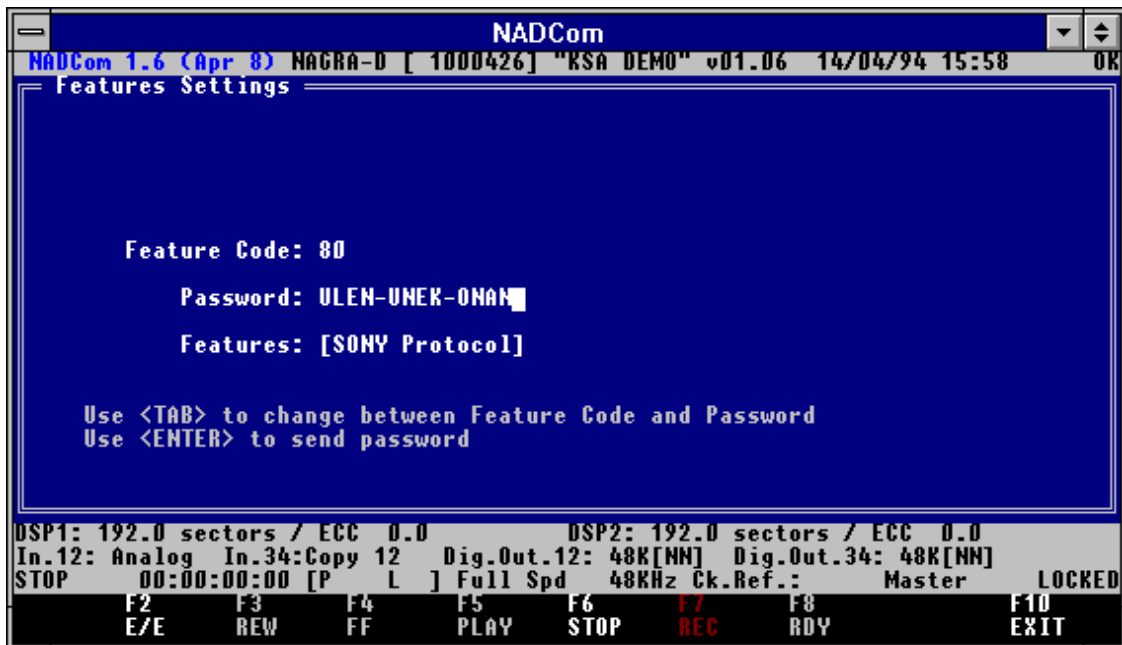

F FEATURE SETTINGS

If "F" is pressed from the main menu screen, the PC display will switch to the FEATURE SETTINGS screen. This screen is used to activate certain options within the machine. For example if the SONY protocol is purchased, then a feature code identification number along with its corresponding password will be supplied (which corresponds to the particular serial number of the machine) and when these numbers are entered via the PC, then the SONY protocol will be activated. The RS 422 menu will then appear in the menu tree under the sub-heading other settings.

The features line is simply to indicate the current options installed in the machine.

In order to move from one position to the next, press the TAB key and use the RETURN (enter) to send the new settings once they have been entered from the PC's keyboard.

L TAPE DIRECTORY MANAGEMENT

NADCom										
NADCom 1.6 (Apr 8) MAGRA-D [1000426] "KSA DEMO" v01.06 14/04/94 15:58 OR										
Tape Directory Management										
DIR	Take	Duration	Date	Timecode	Title	Drops	Level			
	DIR	00'08"	28/04/94	08:43	KSA DEMO TAPE					
	1	00'13"	28/04/94	09:31	12:45:15 Initial test		-16.2dB			
=>	2	05'09"	28/04/94	09:34	12:47:29 Touch tape	3	-0.5dB			
	3	00'58"	28/04/94	09:39	12:52:45 Conversation	1	-0.0dB			
	4	01'06"	28/04/94	09:40	12:53:57 Telephone call		-11.2dB			
	5	01'44"	28/04/94	09:41	12:55:12 Overload / Drop	3	-0.0dB			
	6	03'46"	28/04/94	09:44	12:57:24 Input overload	3	-0.1dB			
	7	01'44"	28/04/94	09:48	13:02:03 CH 1+3 UNCAL		-19.1dB			
	8	00'46"	28/04/94	09:50	13:04:13 CH 2+4 UNCAL		-22.9dB			
	9	00'27"	28/04/94	09:51	13:05:09		-30.6dB			
	10	00'02"	28/04/94	09:52	13:05:43 Start missed		-45.4dB			
	11	00'30"	28/04/94	09:52	13:05:46 restart		-29.9dB			
	END	(total recorded time: 00:16'39")								
Tape "5AE1F4" (Reel D): 11 takes, 10 drops.						Take 2 +03'14"				
DSP1: 192.0 sectors / ECC 0.0					DSP2: 192.0 sectors / ECC 0.0					
In.12: Analog In.34:Copy 12			Dig.Out.12: 48K[NN]			Dig.Out.34: 48K[NN]				
STOP	00:00:00:00	[P	L] Full Spd	48KHz	Ck.Ref.:	Master	LOCKED		
F2	F3	F4	F5	F6	F7	F8	F9	F10		
E/E	REW	FF	PLAY	STOP	REC	RDY	DROPS	EXIT		

If "L" is pressed from the main menu screen, then the PC will switch to the Tape Directory Management. Operation of the directory mode is explained in chapter 3. This screen not only clearly indicates all the information that is stored in the directory, but also allows the operator to change certain information, as well as to remotely control the machine and send it to certain well defined points on the tape (drop-outs, end of recorded section etc).

The upper design screen is the tape directory showing only the takes and their relevant information, and the lower shows the drop outs in the DROPS mode F9. Both screens are fairly self explanatory however each position is briefly covered here.

The first column is the Take number column, which is automatically incremented each time the machine is put into record. The first horizontal line (effectively TAKE # 0) position is the directory itself and the following horizontal lines are numbered consecutively 1, 2, 3, 4 ..etc.

The second column is the duration of the particular take in minutes and seconds. The third column is the date that the take was recorded followed by the time at which it was recorded. This time is the time from the internal real time clock (RTC) and has nothing to do with the time code option ND-TC.

The next column is the time code location of the start of the take. On NON time code machines, or if the time code READY / SAFE switch was in the SAFE position during the recording, this column will indicate 00.00.00 (Time code frames are not included).

The next column is the title of the take. Up to 16 characters may be added here either during the recording or afterwards, by the operator using the normal keys of the PC. The DIR (take # 0) can also be given a name which is effectively classed as the TAPE name.

The final column gives the number of drops, written next to the actual take, and if F9 "DROPS" is highlighted, the following line indicates the type of problem, on which channels it occurred and the duration of the problem indicated in minutes, seconds and hundredths of seconds. If an error has been indicated, then the duration column will indicate where the drop occurs with respect to the start of the take, indicated in minutes and seconds,

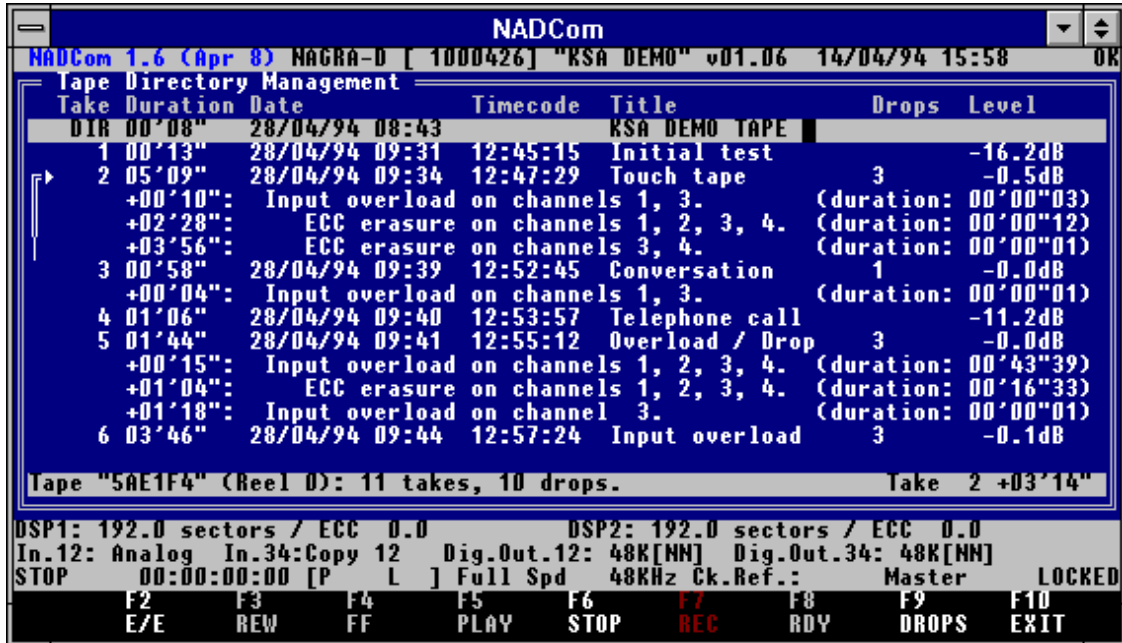

and the display will also show on which channels it occurred. All this can be clearly seen in the diagram.

On the far left side of the screen, there is one (or sometimes two, or even three if there are drop-out or overloads) arrows. The upper arrow indicates in which take the machine is presently, and the second arrow indicates at which drop we currently are. If the line joining the two arrows is a double line then this indicates that the take has already passed, and we are moving towards the next drop.

There is also a cursor "highlighted" bar across the whole screen. This bar can be moved up and down using the normal cursor keys of the PC. Pg Up and Pg Dn will also move this cursor bar to the next screen. When the bar is moved to a particular take, then the operator may type up to 16 characters to add a title to the take (or a tape name if done next to the DIR position). If the operator moves the cursor to a particular take and presses "Control + F5", the machine will go and play back the selected take. "Control + F6" is the "STOP AT" command and "Control + F6" when the cursor is on the last take (marked "END") will send the GOTO END command. Pressing ALT + P will allow the operator to print out the list of takes / drops, which can be placed in the box with the recorded reel. This will work on any type of printer. It has been limited in the number of lines per page so that it can also print on US format paper.

If the cursor is placed on one of the drop-outs or overloads, then the machine will go to the point on the tape but will allow a pre-roll before the error occurs. This pre-roll is approximately 2 seconds at a sampling frequency of 48 kHz.

Along the bottom of this screen are the features activated by the function keys of the PC. F1 and F9 are listed here as they are the only two that are different from other NADCOM screens already explained.

- F1 This is the ZOOM feature which will "ZOOM IN" on a selected take and will indicated (as shown below) graphically the section of tape in question.

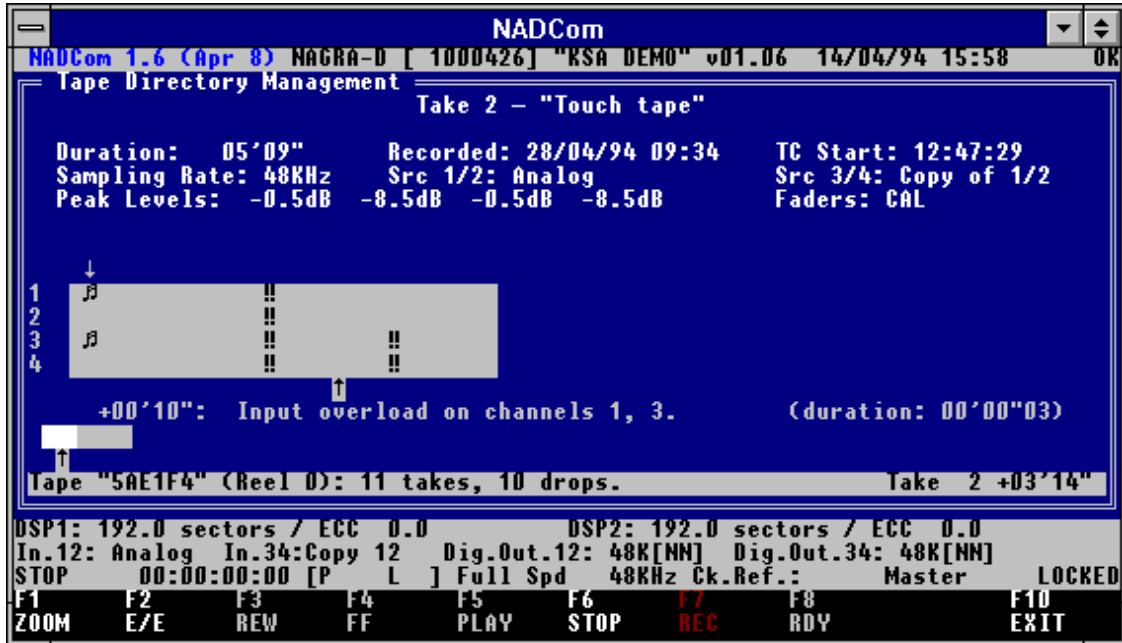

This screen shows one take at a time. The top arrow (near the "1") indicates the drop we wish to hear. This arrow can be moved with the left and right cursor keys. The lower arrow (in reverse video) indicates where the scanner is presently and indicates relative to the whole tape. The music note sign signifies an input overload and the exclamation mark signifies an ECC error.

Other information available on this screen is an indication of the FADERS which will indicate UNCAL if any one of the faders was not in the CAL position at any moment during the take. The position of any input overloads is also marked for each channel corresponding to the position of the upper arrow. The other information on this screen is self-explanatory.

- F9 This is the DROPS key, which gives the possibility of seeing purely the takes (without the drop-out/overload indications) or as above with all the information. This is a toggle function, and is explained above and corresponds to the screen showing drops.



M TIME CODE MENUS

When "M" is pressed from the main menu screen, the Time code Menus are displayed. This screen gives the user access to the internal time code features of the NAGRA-D. The TAB key (or PgUP / PgDn) are used to move around the various options available and the right and left cursor arrow keys are used to change the selection.

The upper left side of the display gives access to the internal time code generator. If the cursor is moved to the FORMAT position then by means of the RIGHT and LEFT arrows on the PC the frame rate of the internal generator can be changed. All the other possible menu choices are modified in the same manner. If the cursor is placed on one of the "SET" positions such as Set time code then the numbers may be entered directly using the numeric keypad. When the desired value has been entered, then press "ENTER" to accept the value. The numbers are entered from the right hand side therefore to enter the time code value of 12H 23M 45S 21F simply type 12234521 followed by ENTER.

Indication of the time code reference point (input delay) and the time code output reference (output delay) is also given (see Menus for further explanation as to their meaning). The right hand upper part of the screen is related to the internal time code chase synchronizer of the machine. The settings are changed in the same way as for time code. The Synchronizer mode position may indicate one of two different things. TSO (as above) is the term used in the AMPEX protocol and stands for Tape Speed Override which within the NAGRA-D corresponds to the VAR CLOCK mode of synchronization. The other indication is Fixed Clock corresponding to the FIX CLK mode in the NAGRA-D.

While in the "set / mod offset" position, the UP and DOWN arrow key can be used to adjust the offset by 1 bit at a time, and in steps of 10 bits if "Shift" is pressed with the UP/DOWN arrow keys.

Directly below these two halves of the screen there is permanent indication of all the time code and values including offset and delta. On this screen the F9 key can be used to send the SYNC command, according to the mode of the internal synchronizer.

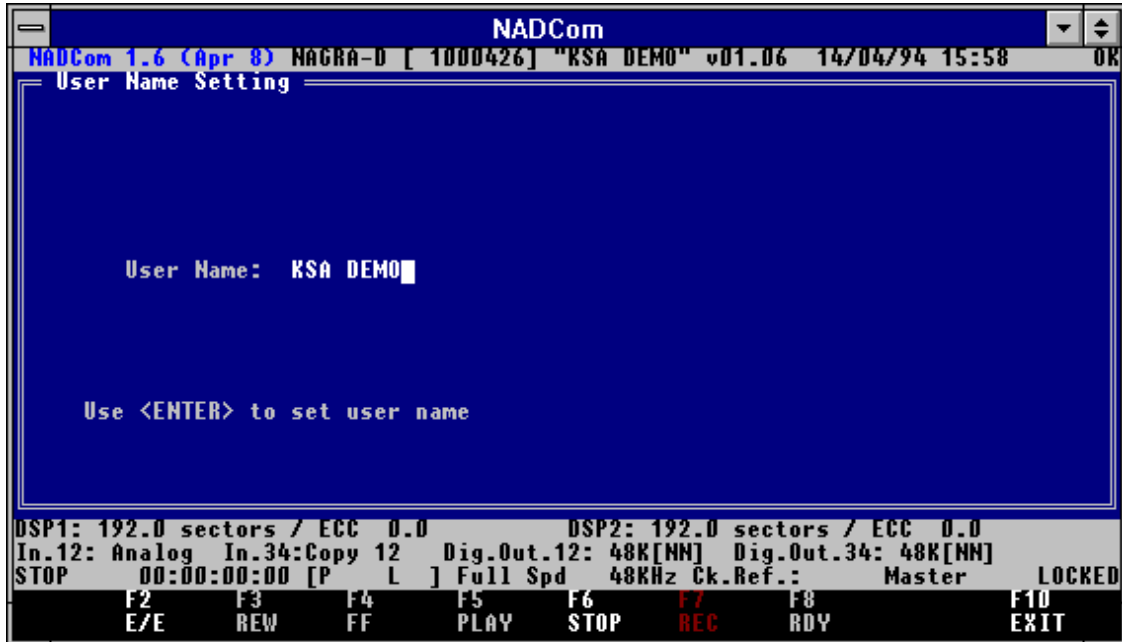

N USER NAME SETTING

If N is pressed from the main menu screen the operator has the possibility to install his or her name or Company name as identification. The name (up to 8 characters) is entered from the PC and will appear on the display of the machine in place of the NAGRA-D originally. This new name can be locked by using a password, obtained from the factory in Switzerland in the same way as the SONY protocol is installed.

This option is simply a security measure and the name, once locked, will not be erased from the permanent memory of the machine.

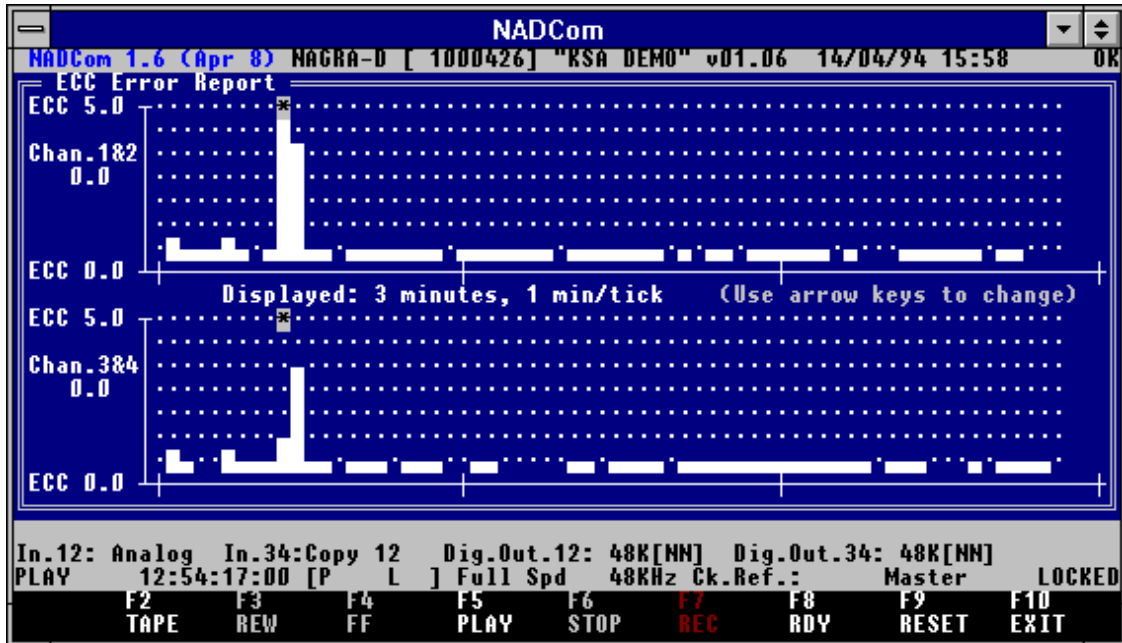

R ECC ERROR REPORT

If "R" is pressed from the main menu screen, then the ECC ERROR REPORT screen will be displayed. This screen shows two graphical displays, the first represents channels 1 and 2 and the second represents channels 3 and 4. Each graphic represents (in the above diagram) a 10 minute section of the tape. The indicated duration can be user selected to be 3 minutes, 10 minutes, 30 minutes, 1 hour or 2 hours by means of the arrow keys. This display is used to indicate the amount of errors along the section, which gives the operator the possibility of studying the quality of the recording on the tape. A FATAL error is indicated by a "*" (see diagram) and all the other errors have been entirely corrected by the ECC. A gap in the bottom line indicates that at that point there were zero errors.

This display can be used during the playback of a tape and serves to indicate at a glimpse whether there have been any uncorrected errors during the take. When the end of the screen is reached, then the screen will scroll horizontally so that the last 3 minutes (in this case) are always on the display.

Below the channel numbers is the instantaneous indication of the present drop-out as was previously indicated at the bottom of the screen.

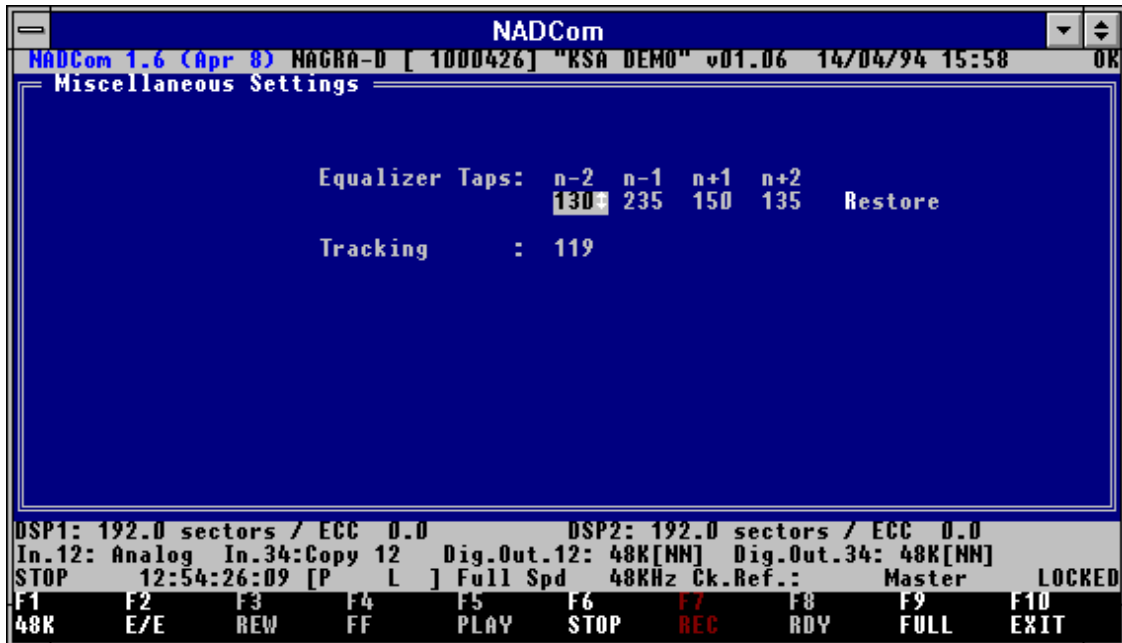

S MISCELLANEOUS SETTINGS

This position give access to the Equalizer settings within the machine, as well as the control track adjustment. The Equalizer Taps settings are factory set but can be modified here. When leaving the program the original factory values will be restored if "R" is pressed or alternatively if the NAGRA-D is switched OFF. These are the adjustments of the preamp on the REC/PLAY circuit to have the correct eye pattern at each sampling frequency. The Tracking position is the calculated offset between the scanner and the control track head. At full speed this setting is always 119 and at half speed it will be between 175 and 245.

On this display screen, the function key F1 can be used to change the sampling frequency of the machine. Each time it is pressed it will toggle through the three possible sampling frequencies in turn. The function key F9 and can be used to change the tape transport speed. Each time it is pressed it will toggle between FULL SPD and HALF SPD.

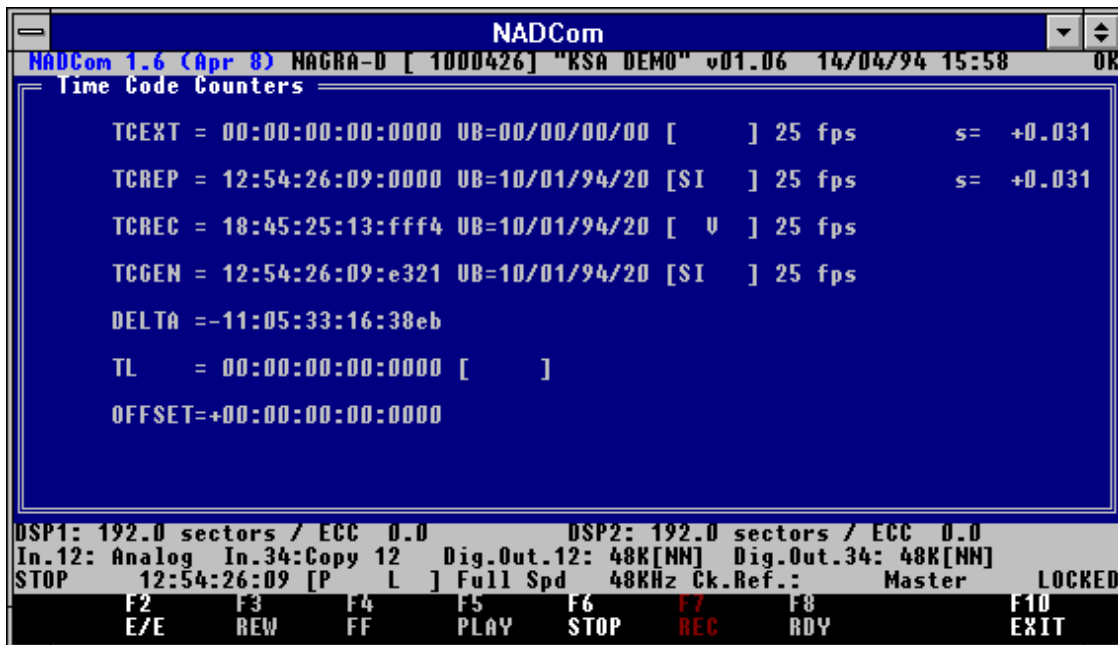

T TIME CODE COUNTERS

Pressing "T" will enter the time code display. This position indicates all the available time code values in the HH:MM:SS:FF format along with the subframes, for the external signal, the time code replayed from the tape, the internal time code generator and the time code to be recorded. The user bits are also indicated next to each time code position. Inside the []'s there is one of five possibilities:

- [V] = Valid time code
- [VB] = Valid backwards
- [S] = Still
- [D] = Discontinue
- [] = Invalid or no time code

After this indication the current frame rate of each position is indicated. Next to the first two positions is the speed indication. This should be 0.00 when stopped and 1.00 when running.

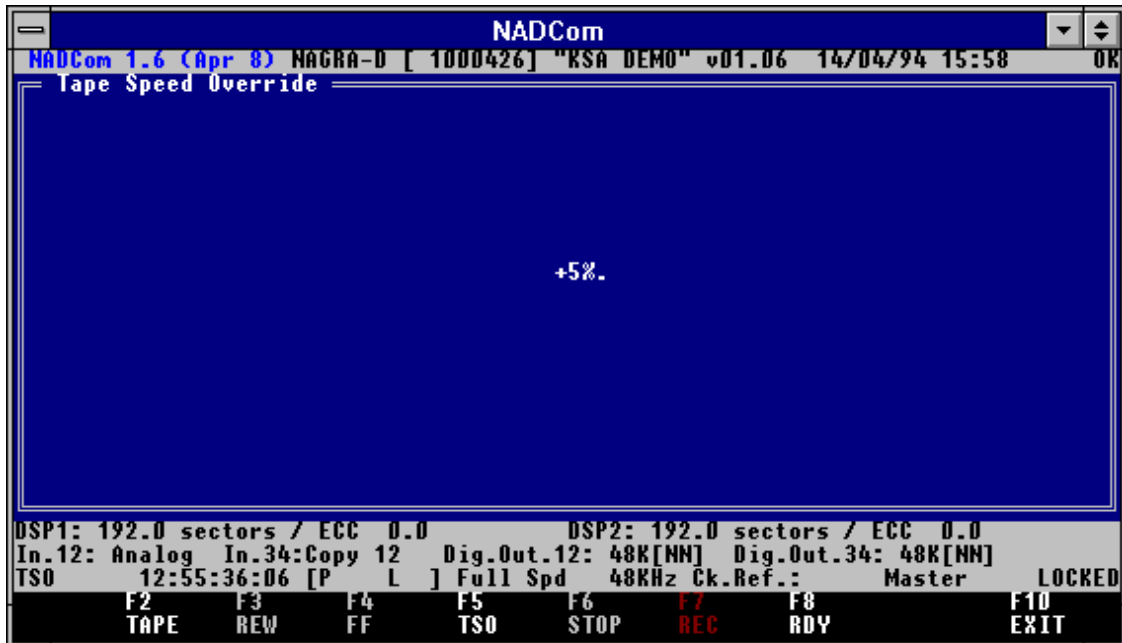

V TAPE SPEED OVERRIDE

In this position the longitudinal tape speed can be modified. The indication in the center is 0% for nominal speed and + or - depending on the selections made. To change the value, either use the UP arrow or DOWN arrow of the cursor keys on the PC, or page UP and page DOWN (to jump in fixed steps) or simply enter the desired value using the numeric keypad, followed by "ENTER".

Q QUIT

When "Q" is pressed the PC will leave the NADCOM program and will return to DOS.

CHAPTER 6

SPECIFICATIONS

Specifications Nagra-D	127
Tape Format / Transport	127
Audio Performance	127
Inputs / Outputs	128
General	128

SPECIFICATIONS NAGRA-D

TAPE FORMAT / TRANSPORT

Recording system	: Rotary heads and 3 Longitudinal tracks
Monitoring	: Read after write
Tape type	: 1/4" (6.35 mm) Digital tape
Tape speed	: 49.6 mm/s for 2 channels 99.2 mm/s for 4 channels
Recording time	: 5" reel (346m) 2 Ch = 2 hr. 4 Ch = 1 hr. 7" reel (692m) 2 Ch = 4 hr. 4 Ch = 2 hr.
Variable speed	: $\pm 10\%$
Search possibilities	: Using longitudinal analog Cue track
Start up time	: From READY to REC better than 2 sec
Winding speed	: 90 secs (for 5" reel)

AUDIO PERFORMANCE

N° of channels	: 2 or 4
Sampling frequencies	: 32 kHz, 44.1 kHz and 48 kHz.
Analogue IN/OUT	: 20 bits
Signal/noise ratio	: Better than 98 dB
Frequency response	: 20 Hz to 20 kHz ± 0.5 dB (48 kHz sampling frequency)
Total Harmonic distortion	: Less than 0.05%
Wow and flutter	: Below measurable limits
Channel separation	: 80 dB
Digital IN/OUT	: 24 bits (AES)
Error correction	: Reed Solomon (38,34,5) (12,9,4)

INPUTS / OUTPUTS

Analogue inputs	: Switchable Line or Microphone
Microphone	: 4 XLR (switchable, 12V "T" power, Phantom +12V, Phantom +48V)
Line	: Symmetrical, transformerless ($Z_{in} > 8\text{ k}\Omega$)
Analog outputs	: Symmetrical, transformerless on XLR connectors 3.1V max ($Z_{out} = 50\Omega$)
Digital I/O	: AES (standard mode)
Time code I/O	: SMPTE/EBU symmetrical (balanced)
External sync	: PAL / SECAM / NTSC / EXT / AES / TC
Serial communication	: RS 422 9-pin
Headphone outputs	: 2 x Stereo ($Z_{out} 2 \times 47\text{ S}$) with stepped level adjustment (1.45V @ 0 dB no-load)

GENERAL

Power requirement	: Internal battery pack
Battery type	: Betacam (4.5 Ah 12V)
Autonomy	: 1 hr 45 mins.
Consumption	: STOP = 24 W REC = 29 W
External dimensions	: $13\frac{1}{16} \times 13\frac{21}{32} \times 5\frac{5}{8}$ " (LxWxH) (332 x 347 x 143mm)
Weight (batt incl)	: 8.5 kg (18.7 lbs)

CHAPTER 7
OPTIONS AND ACCESSORIES

Internal Options	130
External Options	131
Internal Accessories.....	131
External Accessories	131

This section is a quick reference guide to the various different accessories and options that are available for the NAGRA-D. Each option is described in detail and its corresponding code number and symbol are also indicated.

KSA#	SYMBOL	Description
10002	NAGRA-D	This is the NAGRA-D recorder itself, which is equipped with 20 bit internal A/D converters and is delivered with an internal battery pack (BP-90 5Ah 12V), a 5" take-up reel, a 5" roll of digital tape, a short format reference check tape which allows the user to verify the alignment of his machine and an operating manual (English).

INTERNAL OPTIONS

10200	ND-VCLO	Variable sync input. This is a small internal electronic circuit which is added to the clock board. It allows the digital outputs to be used when the machine is slowed down by 0.1%. This is only used when slowing down from 30 frames per second time code to 29.97 frames per second in NTSC countries during post-production.
10210	ND-422S	The SONY remote control RS 422 protocol is a software option which is activated in the machine by entering a password using a computer which is equipped with the NADCOM software. This password can only be issued from the KSA factory. Once the password has been entered the SONY protocol menu will appear automatically. Once it has been activated this authorisation is stored in the E ² prom and will never need to be entered again even if the software of the machine is changed.
10215	ND-HSF	The High Sampling Frequency a software option which allows the NAGRA-D to indicate correctly on modulometers 1 and 3 and to select the headphone monitoring correctly to channels 1 and 3 only when working with external A/D converters which sample at 64, 88.2 or 96 kHz. It is activated in the machine by entering a password using a computer equipped with the NADCOM software. This password can only be issued from the KSA factory. Once the password has been entered the high sampling frequencies will appear in the sampling frequency menu automatically. Once it has been activated this authorisation is stored in the E ² prom and will never need to be entered again even if the software of the machine is changed. This option DOES NOT mean that the internal A/D converters of the machine will sample at high sampling frequencies. External converters must be used.
10230	ND-AP	Not to be confused with the AUTO-POWER MENU which is a power saving feature available on all machines, the Auto-power option is an internal electronic circuit allowing an external D.C. supply from +11V to +14Vmax to power the machine. using such an external supply will NOT charge the internal battery of the NAGRA-D.
10323	ND-IL	The line input circuit should be used when the analogue inputs of the NAGRA-D are to be fed with line level signals. This option is a circuit board that is installed inside the machine, and is equipped with two sets of switches. These switches allow the user to select either LINE inputs or MIC inputs as well as the desired output level of either 3.1V or 4.4V
10370	ND-TC	The SMPTE/EBU Time Code board is installed inside the machine and is equipped with a chase synchronizer. It can be installed on any NAGRA-D as all machines are pre-wired for the time code option.

EXTERNAL OPTIONS

- 10514 ND-SNC Software "NADCOM" Version PC (3.5" diskette). The NADCOM software is only available in the PC format and is delivered on a single diskette. It is a DOS based program and it is recommended to close WINDOWS before running the program. A full explanation of the different features offered by this software is covered in chapter 5 of this manual.
- 10520 ND-SET This accessory is a large lid for 7" reels which is mechanically mounted around the deck plate of the recorder. When this option is installed the position of the carrying handle can be changed in order to allow the machine to be carried from the back rather than the front in the conventional manner.
- 10550 ND-LIA If the ND-IL line input board is not fitted to the machine, then a line input attenuator can be plugged into each analogue input to allow a line level signal to be fed to the machine.
- 10560 ND-PP This potentiometer protection bar can be screwed onto the front of the machine in front of the fader potentiometers which serves as a protection to avoid them being accidentally moved during operation of the machine.

INTERNAL ACCESSORIES

- 98400 ND-BP Reserve battery pack BP-90 NiCd (5Ah 12V). Although the NAGRA-D is delivered with an internal battery pack, additional batteries may be needed especially if the ND-AP auto power option is being used.

EXTERNAL ACCESSORIES

- 10505 ND-EPC The external DC/DC power converter, which is similar in size to the regular A.C. power converter, will allow any external D.C. supply from 11 to 30V to be connected to the machine. This option will charge the internal battery in the same way as the A.C. charger. It is especially useful when running the NAGRA-D on a sound cart. This option is fitted with a 4 pole male XLR connector to which the external D.C. is connected.
- 10755 ND-CCC3 The current control charger with cable is the standard A.C. mains power supply and charger. This supply will charge the internal battery of the machine as long as the NAGRA-D is switched on and is in the PARK or LOAD position. The charge current that it supplies is determined by the microprocessor of the machine.
- 10530 ND-CM The commentary microphone is a hand-held microphone that can record on the analogue CUE track while the NAGRA-D is in REC mode. It can be used for laying commentary down and is connected to the EXTENSION connector on the left side of the machine.
- 10540 ND-PCA This RS 232 / 422 adapter needs to be used if the NAGRA-D is to be connected to a PC running the NADCOM software. The connection protocol of the NAGRA-D corresponds to RS 422 and most PC's (especially Laptops) only communicate using RS 232. This small adapter requires no additional powering and converts the RS422 to RS232. It need not be used if the PC is equipped with an RS 422 port.
- 10752 ND-MENU This is a laminated copy of the entire menu tree as shown at the beginning of chapter 3 of this manual. It simply allows the user to have a full copy of all the menus to hand for quick reference during operation of the machine.
- 91760 ND-TT This is a calibration tape for the NAGRA-D and would only be used when checking or re-aligning a NAGRA-D. full explanation of the use of this tape is covered in the service manual.

97750	QDT-13	A 5" reel of metal oxide digital tape type: Quantegy 467
97760	QDT-18	A 7" reel of metal oxide digital tape type: Quantegy 467
97755	BDT-13	A 5" reel of metal oxide digital tape type: BASF 931
97800	BOB-A	A 5" empty plastic reel.
97802	BOB-18	Plastic take-up reel (7")
97751	ND-TIS	A sheet of 30 stickers which can be stuck on to the plastic reels for for tape identification purposes.
99050	ND-SCC	Soft carrying case (for NAGRA-D without ND-SET large reels cover)
10231	ND-APC	Spare cable for the ND-AP auto-power option.
10901	DCR	Mike Cable DIN3F-XLRM 1.5 m
10905	ND-RSC	Special cable needed to make mirror copies of tapes between two NAGRA-D machines.
10906	ND-SSC	Special cable needed to perform sample sync recording and reply using two NAGRA-D machines.
16908	QCTC	TC Cable Lemo male - Lemo male 1.5 m This cable would be used to connect the time code of the NAGRA-D to any other NAGRA time code product.
16909	QCTCU	TC Cable Lemo male - Lemo male to open end 1.5 m This cable can have any type of connector fitted to the open end, and hence allow connection to any other time code machine.
95970	CXLR-FM	3-pin XLR male-female microphone / AES 1.5 m
95971	CXLR-FF	3-pin XLR Cable female-female 1.5 m
95972	ECXLR-FM	3-pin XLR extension cable male-female 10 m

A	
Absolute Time	40
Aes Bus Synchronization	93
Alarm Led	23
Analog Measures	112
Analog Output Connections	3
Analogue Audio Output Connectors	32
Analogue Input Connectors	29
Audio Channel Lock Out Switches	23
Audio Settings	115
Auto Power Off Feature	55
B	
Batt Led	23
Battery Capacity	46
Battery Charge	46
Battery Removal	78
Battery Reserve Display	46
Beep Function	54
C	
Cal Led	24
Carrying Handle	32
Chase Mode	44
Chase Mode Under Sony Control	106
Chase Synchronise Mode	20
Control Track	6
Copy Function Menu	60
Copying Of A Nagra-D Tape	74
Cue Channel Lock Out	23
Cue Microphone	65
Cue Track	6, 65
D	
Digital Input Connectors	29
Digital Output Connectors	32
Directories Menu	52
Directory Contents	80
Discontinuity Handling	45
Display (L.C.D) Indications	101
Display 2	40
Display Illumination Switch	16
Display Messages	89
Display Selection	39
Displaying A Time Code	95
Down Arrow	22
E	
Ecc Error Report	122
Edit Mode	67
Edit Mode Selector	24
Editing (Rs 422 Control)	103
Ee / Auto / Tape Selector	16
Electrostatic Discharge	3
Escape Feature	22
Exe Key	22
Extension Connector	30
External Dc Powering	10
External Sync	94
F	
Fader Command Source	58
Fader Control	17
Fader Menu	58
Fader Pot All Calibrate	58
Fader Pot Assign	58
Fast Forward Key	21
Feature Settings	116
Filter Switch	26
Fix Clk	45
G	
Gen Out	44
General Description Of Nagra-D	1
Generator Format	42
Generator Mode	43
Generator Recording Source	42
Goto End Function	19
Goto Zero Feature	20
H	
Head Cleaning	4
Headphone Connectors	32
Headphone Level Control	32
Headphone Mode Selector	2-14
Headphone Selection	2-14
Headtime	56
Helical Tracks	7
Hold Max	16
I	
Input Level Sensitivity Adjustment	17
Input Phase Source	58
Inputs Selection Menu	47
Insert And Assemble With Directories	85
Interactive Control Panel	114
Internal Generator Setting	96
L	
Large Reel Operation	8
Lcd Display	22
Led Indications Of The Nd-Epc	10
Level Position	16
Line Input Circuit	73
Loading A Tape	34
Longitudinal Tracks	6
M	
Main Control Panel	2-14
Main Menu Screen	110
Memory Reset	56
Menu Displays	61
Menu Mode	36
Meter Switch	16
Meters	17
Microphone Inputs	68
Microphone Powering Selectors	29
Mirror Copy	75
Miscellaneous Settings	123
Monitoring	66
N	
Nadcom Software	109
Nd-Ap Option	10
O	
Other Settings Menu	53
Overload Leds	24
P	
Phase Selector	26
Play Key	20
Playing Back A Recorded Tape	74
Power Button	23
Power Connector	32
Power On	34
Powering The Nagra-D	9

Protocol	104
<i>R</i>	
Reactime Of The Synchroniser	45
Ready Key	19
Real Time Clock.....	55
Rec Leds	17
Record Key	19
Record Previous - Use Of	83
Record Previous Feature.....	19
Recording.....	72, 81
Recording A Digital Signal	73
Recording A Line Input	73
Recording With Microphones.....	72
Reel Nb Selection	52
Ref.Freq Under Sony Control	106
Reference Frequency Selection.....	49
Reference Generator Level.....	47
Reformat Tape Directory.....	52
Remaining Time	39
Reset Counter Command	19
Reset Hold	16
Rewind Key	21
Right Arrow	22
Roller.....	39
Rs 422 Connector	30
Rs 422 Menu.....	56

S

Sample Sync Feature	103
Sampling Frequency Selection	48
Scanner Ready Time	55
Search Backwards Command	20
Search Forward Command.....	20
Set Generator	43
Setting From External	98
Skip Back One Take	21
Skip Features.....	85
Skip Forward One Take	21
Software Version.....	56
Specifications Nagra-D	127
Stop Key	20
Sync And Sync Incremental.....	100
Sync Mode Understanding Of.....	107
Synchronisation	105
Synchronization Possibilities.....	92
Synchronization Using Time Code.....	100

T

Tail Out Tapes	83
Take Number	39
Tape Care / Handling.....	3
Tape Counter	102
Tape Deck.....	2-14
Tape Directories Explanation	79
Tape Directory Management	117
Tape Durations	2
Tape Format Menu	42
Tape Speed	7
Tape Speed Override.....	125
Tape Speed Selection.....	51
Tape Tension Selection	55
Tc Delay Menu	43
Tc Delta Display	40
Tc Display	40
Tc Offset	44
Tc Out Display	40
Tc Rec Display.....	40
Tc Recording Source Selection	96
Tc Setting From External	98
Template Menu	58
The Nd-Epc.....	10
Time Code	95

Time Code Assemble	97
Time Code Channel Lock Out	24
Time Code Counters	124
Time Code Delay Setting	98
Time Code Format Selection	96
Time Code In / Out.....	29
Time Code Menus	120
Time Code Recording	98
Time Code Replay.....	99
Time Code Selection.....	41
Time Code Track.....	6
Tracking Feature Use Of.....	86
Tracking Mode Selection.....	54

U

User Name Setting.....	121
------------------------	-----

V

Var Clk.....	45
Vclo 14 Mhz.....	50
Video Reference.....	93
Video Sync Connector	29

W

Winding Speed	55
Write Protection.....	52

