

24 FEV. 1988

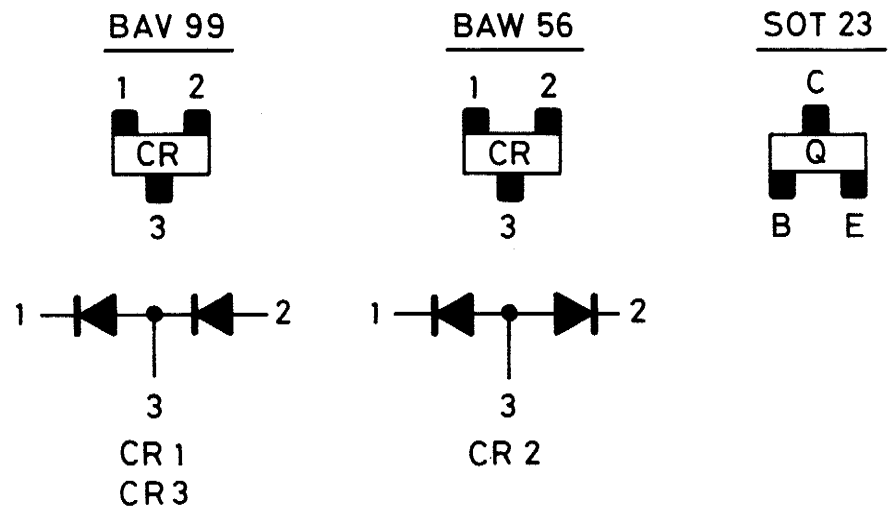
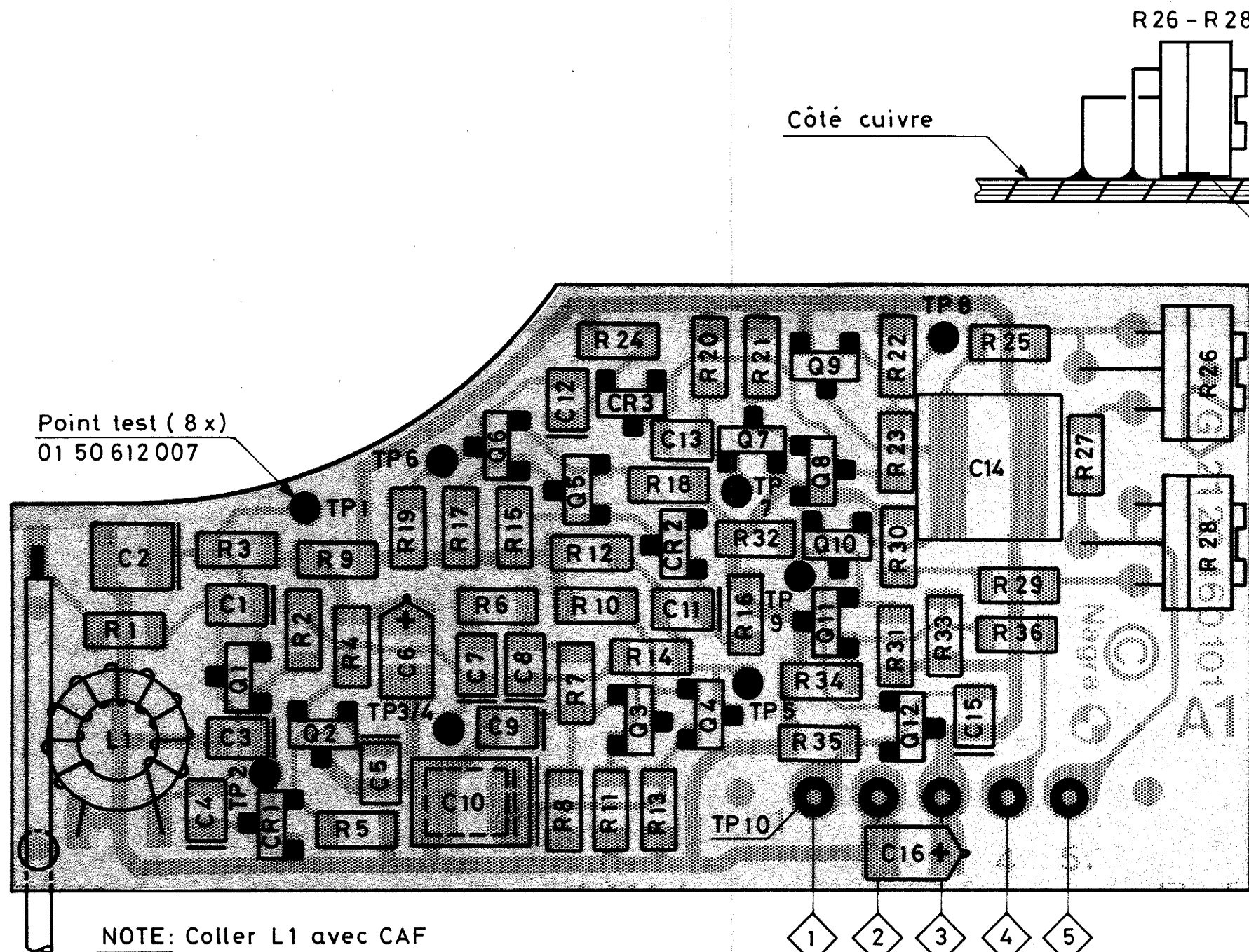

Valable pour circuit indice **G**

NAGRA KUDELSKI	Modif.	1	2	3	4	5	6			
	Matière									
	Désign.									
	Dimens.									
Fam. pièces	Plan d'implantation						Echelle	Dessiné	7.12.84	Király
Copie à	Stabilisateur de vitesse						4:1	Visa		
	SNN / S						91 20 460 100			