

## NAGRA VI SERVICE BULLETIN

### APPLICATION

- To use an external HDD (without external power) with a current drain above 500 mA.
- To be electronically ready for using simultaneously an external HDD and a keyboard. This needs an additional PCB and a new right side panel (USB HOST-2).

### MODIFICATION

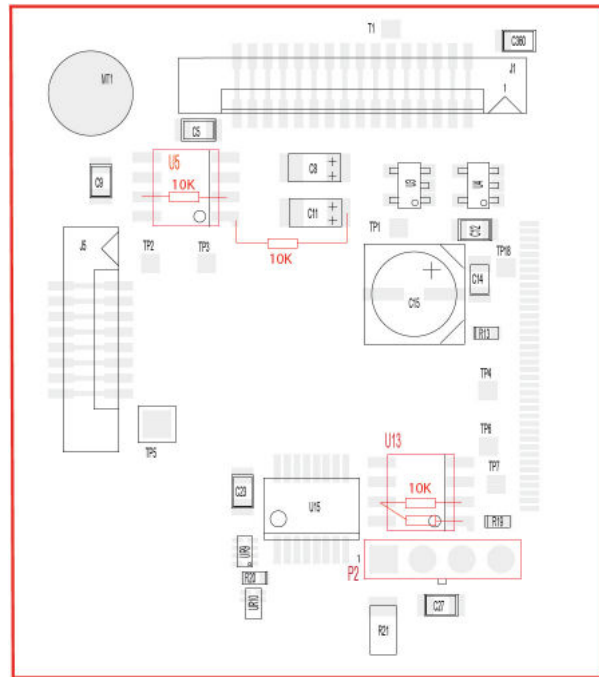
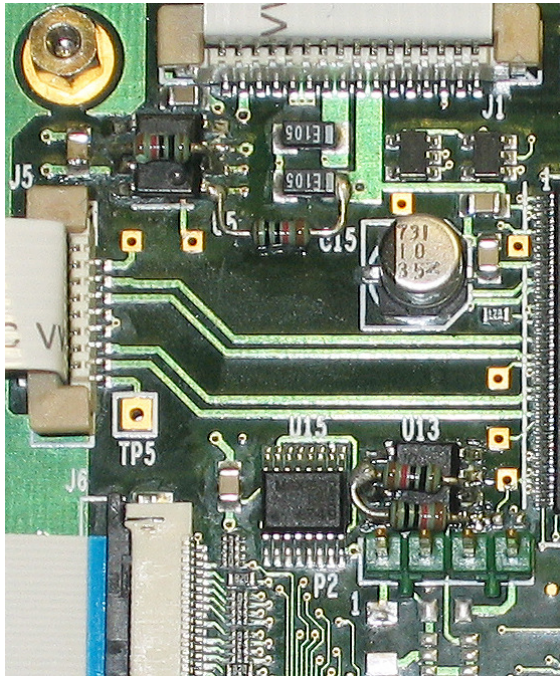

- Remove the bottom of the Nagra VI.
- In case that the TIE 32-02 was applied, remove the 2 resistors of 10K around U5 and the 10K resistor above U13.
- Remove U5 and replace it by a LM3525M-L.
- Solder the 2 resistors of 10K between U5 pin 2 & 7 and between U5 pin 1 and C11+.
- Solder U13 MIC 2025-2YM.
- Solder the 2 resistors of 10K between U13 pin 2 & 7 and between U13 pin 1 & 7.
- Solder the connector P2 (to execute this, the board must be removed).

### PARTS

4x 10 kΩ 1/8 Watt	Part number: 5527182103
1x LM3525M-L	Part number: 5443202525
1x MIC 2025-2YM	Part number: 5443202520
1x 4 pin connector	Part number: 4020431041

**SCHEMATICS**

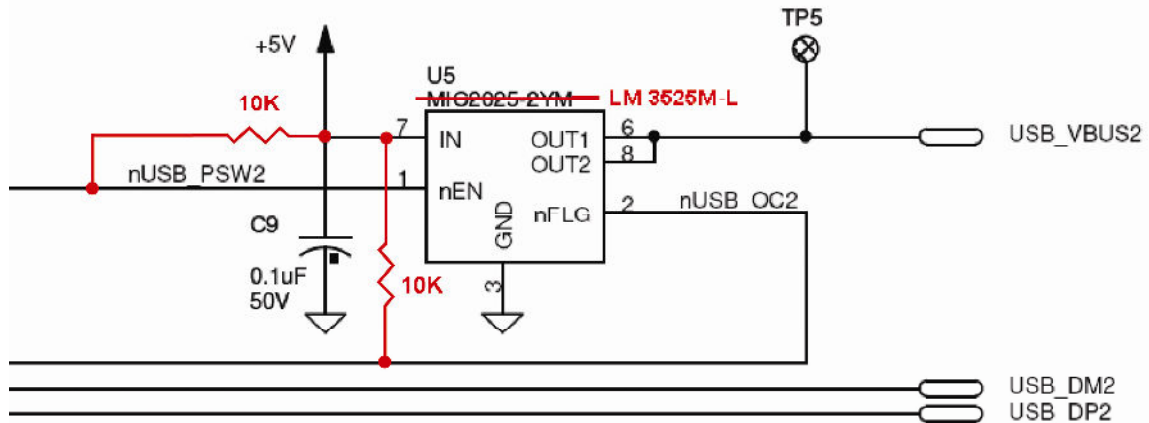

**COMPONENTS NOT MOUNTED**

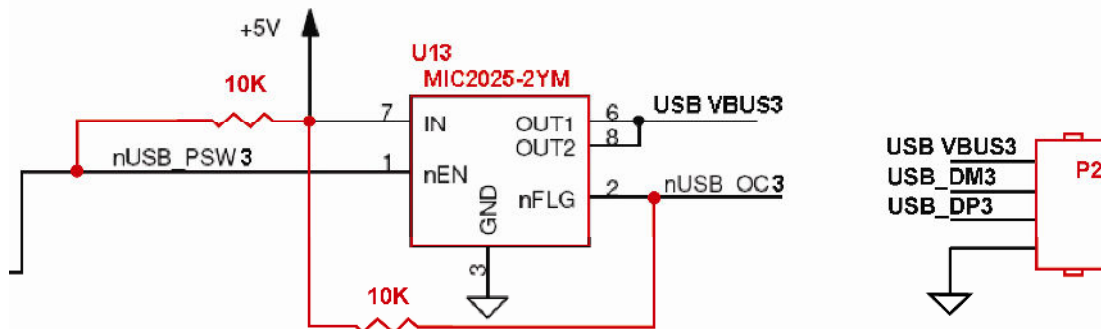
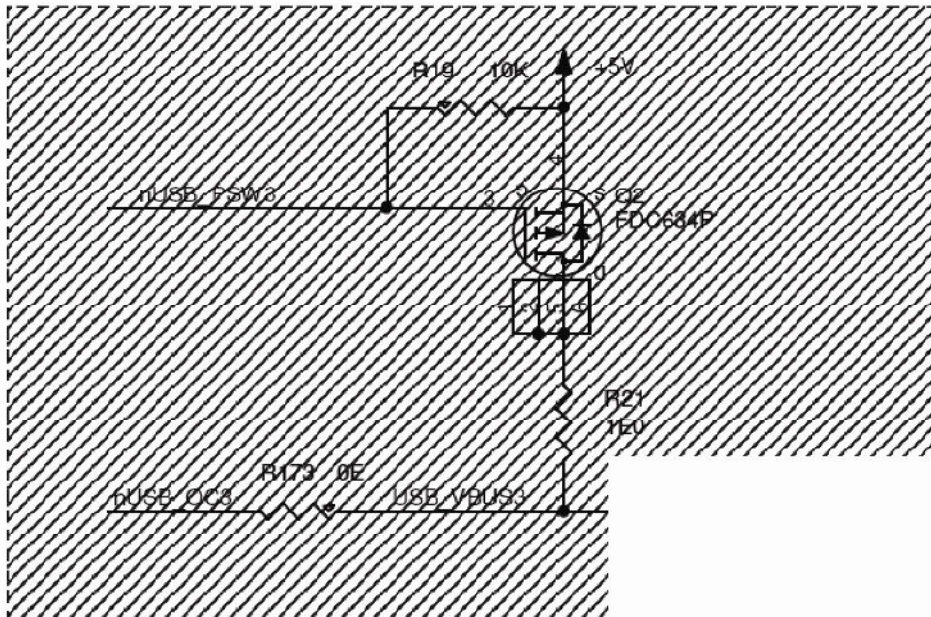

019)  
 NAGRAVISION SA  
 JULY 2, 2009

(OME32)